

CUSTOMSETTER INSTALLATION INSTRUCTIONS

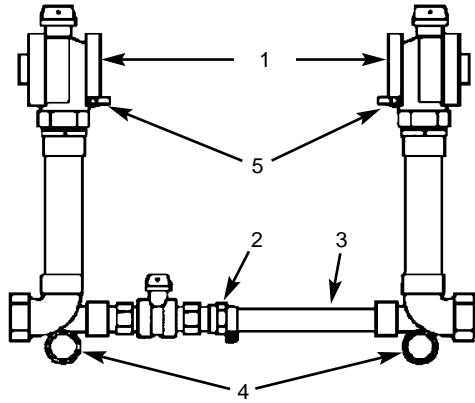

1. **CHECK LAYING LENGTH OF METER WITH SETTER DIMENSIONS (#1).**
Adjustments to setter meter length may be made as follows:
 - A. **LOOSEN PACK JOINT (#2) AND ADJUST SETTER LENGTH TO FIT METER BY INSTALLING PROPER IDLER OR METER.**
 - B. If a shorter meter is used, cut the copper pipe (#3). Copper pipe should extend a minimum of 1/2" beyond the Pack Joint gasket.
 - C. Tighten Pack Joint (#2) nut and screw.
2. Cut two pieces of 1" pipe 18" long and install through the brace eye supports(#4).
3. Be sure that the Customsetter is installed in the correct position in relation to the water flow and make sure the bypass valve is in the **OFF** position.
4. Use a good pipe sealant or Teflon tape when attaching fittings to the female iron pipe inlet and outlet threads.
5. Special Ford drop-in gaskets are included with each setter for use when installing the water meter. Meter support brackets (#5) may need to be loosened or removed due to variations in the shape of water meter flanges.

HIGH BYPASS CUSTOMSETTER INSTALLATION INSTRUCTIONS

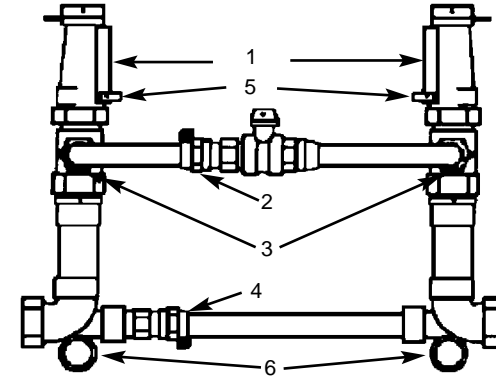

1. **CHECK LAYING LENGTH OF METER WITH SETTER DIMENSIONS (#1) AND INSTALL METER OR METER IDLER PRIOR TO CONNECTING THE BYPASS ASSEMBLY AND THE INLET AND OUTLET SERVICE LINES.**
2. The bypass assembly has been removed for shipping and may be re-assembled as follows:
 - A. Loosen Pack Joint (#4) on Customsetter brace bar.
 - B. Loosen Pack Joint on bypass ball valve (#2).
 - C. Insert bypass ends completely into the Pack Joint Assemblies (#3).
 - D. Tighten all Pack Joints (#2, #3, and #4) securely with meter or meter idler in place.
3. Cut two pieces of 1" pipe 18" long and install through the brace eye supports (#6).
4. Be sure that the Customsetter is installed in the correct position in relation to water flow and make certain the bypass valve is **OFF**.
5. Use a good pipe sealant or Teflon tape when attaching fittings to the female iron pipe inlet or outlet threads.
6. Special Ford drop-in gaskets are included with each Customsetter for use when installing a water meter. Meter support brackets (#5) may need to be loosened or removed due to variations in shape of water meter flanges.



The Ford Meter Box Co., Inc. 775 Manchester Avenue, P.O. Box 443, Wabash, Indiana, USA 46992-0443
Telephone: 260/563-3171 FAX: 1-800-826-3487 Overseas FAX: 260/563-0167 <http://www.fordmeterbox.com>



The Ford Meter Box Co., Inc. 775 Manchester Avenue, P.O. Box 443, Wabash, Indiana, USA 46992-0443
Telephone: 260/563-3171 FAX: 1-800-826-3487 Overseas FAX: 260/563-0167 <http://www.fordmeterbox.com>