

Ford 2" Dual Check Valve Repair Kit (HHRK-7)

Field Instructions

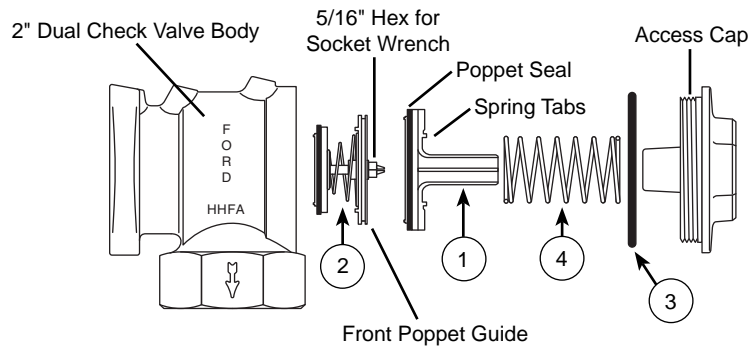

Item #1	Rear Poppet	Item #2	Front Poppet Assembly
Item #3	O-Ring	Item #4	Rear Spring

Figure 2

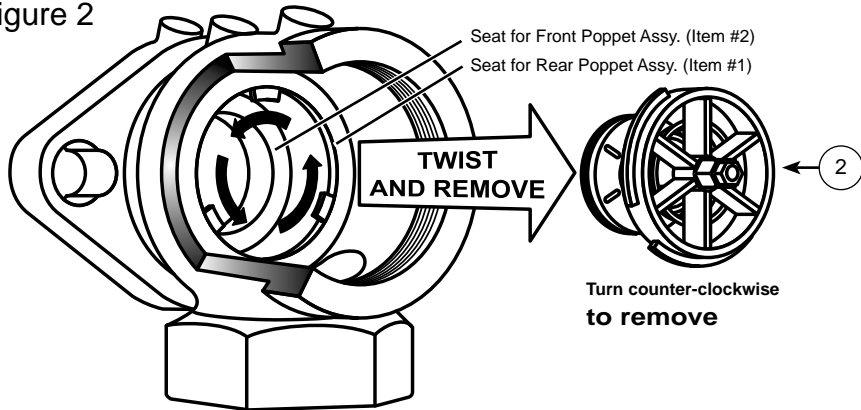
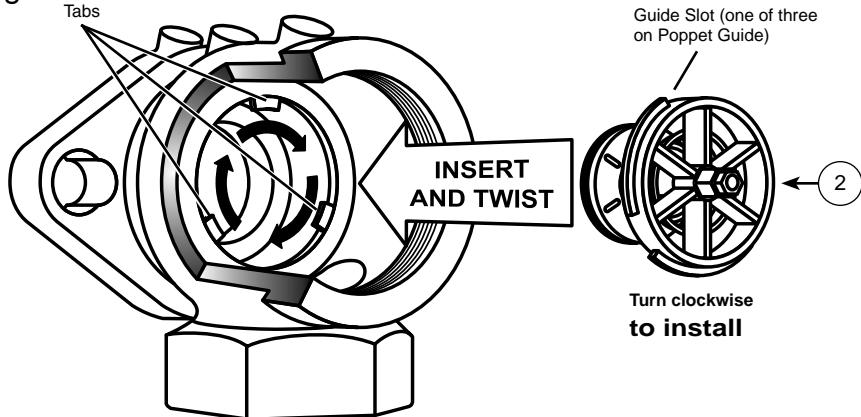

Figure 3



1. Locate the stamped model number on the valve body. 2" Dual Check Valves will be marked as HHFA or HHS - both types require Repair Kit Number HHRK-7.
2. Shut off inlet water supply going to the Dual Check Valve. Shut off and/or drain customer's side of water supply.
3. Carefully remove Access Cap, Rear Poppet Assembly and Spring - parts are spring loaded.
4. Using a 5/16" socket wrench on the Front Poppet Guide hex, remove Front Poppet Assembly (see Figure 2, Item #2) by turning approximately 30 degrees counter-clockwise with wrench. Assembly is spring loaded and will "pop" out once Guide Slots and Tabs are aligned.
5. Inspect brass seats in valve body. Replace entire Valve if seats are worn or corroded.
6. To reassemble Check Valve, refer to diagrams and follow instructions #7 through #11.
7. Install new Front Poppet Assembly (see Figure 3, Item #2) by putting hex end of Guide in socket wrench. Insert wrench and Poppet Assembly into Valve until Poppet Seal rests on seat. Line up Guide Slots and Tabs by turning with light pushing pressure until Poppet Guide slides over Tabs. Turn clockwise about 30 degrees or until Guide stops.
8. Remove O-ring from Access Cap and replace with new one (see top diagram, Item #3).
9. Put Spring (see top diagram, Item #4) on Rear Poppet Assembly (Item #1), centering it within Spring Tabs (see top diagram). Insert Spring and Poppet into Valve making sure Poppet Seal is centered on Valve Body Seat.
10. Install Access Cap by compressing Spring while tightening Cap into Valve Body. Torque Cap to about 10 ft-lbs.
11. Turn on inlet water supply and insure the Access Cap is water tight.