

# SUBMITTAL INFORMATION

**Ball Valve Curb Stop Minneapolis Pattern  
with Stop and Waste - (B44-xxxSWM-Q style)**

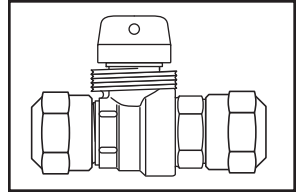

## QUICK JOINT FOR COPPER OR PLASTIC TUBING (CTS) INLET AND OUTLET

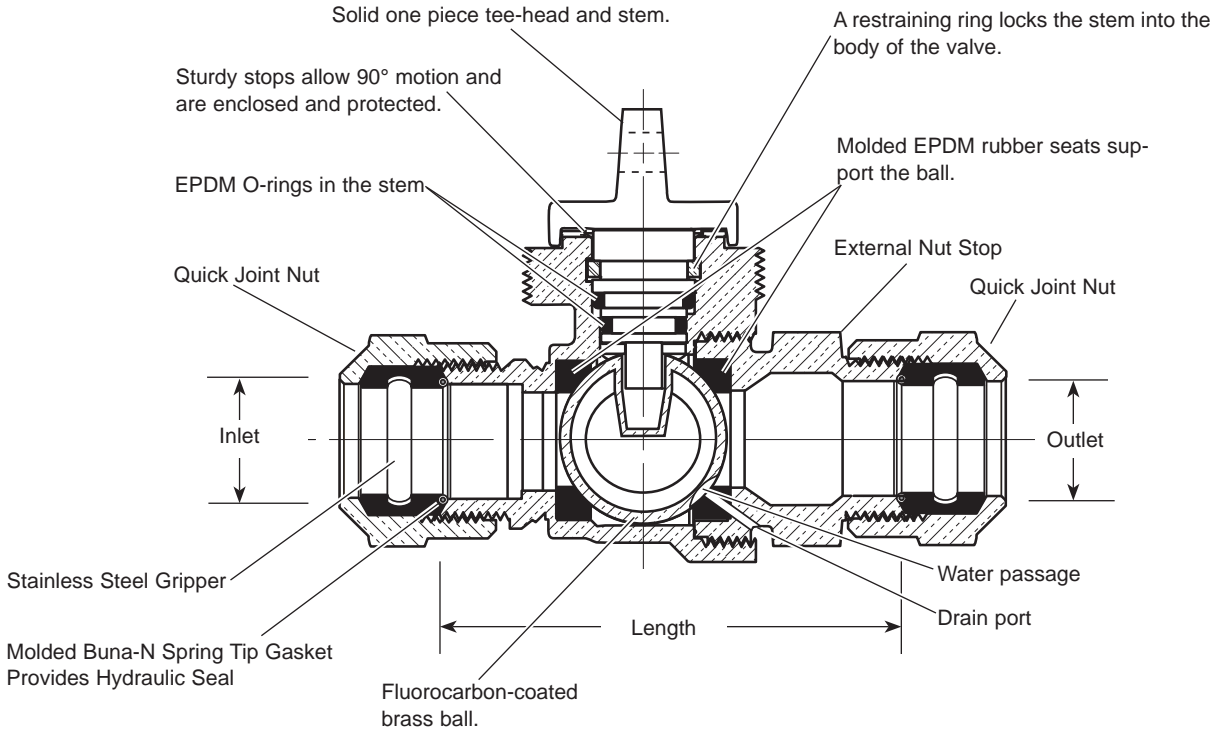

VALVE SIZE	INLET SIZE	OUTLET SIZE	LENGTH	APPROX. WT. LBS	PART NUMBER	✓ SUBMITTED ITEM(S)
3/4"	3/4"	3/4"	3-15/16"	2.4	▼ B44-333SWM-Q	
1"	1"	1"	4-13/16"	3.2	▼ B44-444SWM-Q	

▼ UL Classified to ANSI/NSF Standard 61.

**Note:** Ford recommends using insert stiffeners with plastic pipe or tubing.



## FEATURES

- All brass conforms to AWWA Standard C800 (ASTM B-62 and ASTM B-584, UNS NO C83600 - 85-5-5-5)
- Ends are integral or secured with adhesive to prevent unintentional disassembly.
- Hole for attaching curb box rod.
- 150-175 PSI working pressure.

The Ford Meter Box Company considers the information in this submittal form to be correct at the time of publication. Item and option availability, including specifications, are subject to change without notice. Please verify that your product information is current.



**The Ford Meter Box Company, Inc.**

P.O. Box 443, Wabash, Indiana U.S.A. 46992-0443

Phone: 260-563-3171 / Fax: 800-826-3487

Overseas Fax: 260-563-0167

<http://www.fordmeterbox.com>

10/22/07

Submitted By: