

SUBMITTAL INFORMATION

Straight Ball Yoke Valves - (B96-xxxW-G style)

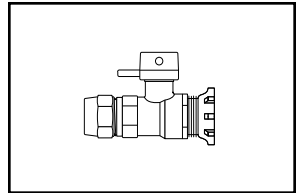

GRIP JOINT FOR POLYETHYLENE PIPE (PEP) INLET BY METER YOKE NOSE OUTLET

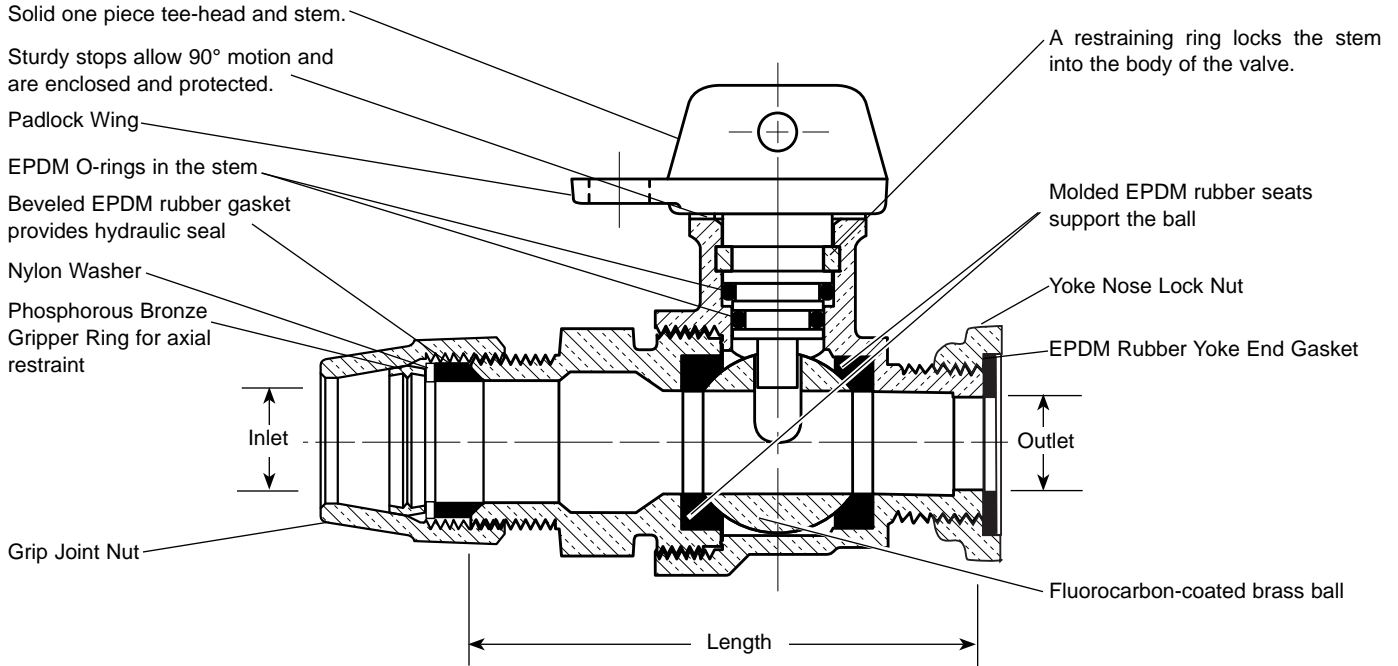

VALVE SIZE	INLET SIZE	OUTLET METER SIZE	LENGTH	APPROX. WT. LBS	PART NUMBER	✓ SUBMITTED ITEM(S)
3/4"	3/4"	5/8"	3-7/8"	2.3	▼ B96-313W-G	
3/4"	3/4"	5/8"x3/4" & 3/4"	3-7/8"	2.3	▼ B96-323W-G	
3/4"	1"	5/8"	3-7/8"	2.7	▼ B96-314W-G	
3/4"	1"	5/8"x3/4" & 3/4"	3-7/8"	2.7	▼ B96-324W-G	
3/4"	1"	1"	4-1/2"	3.4	▼ B96-344W-G	



▼ UL Classified to ANSI/NSF Standard 61.

Note: Ford recommends using insert stiffeners with plastic pipe or tubing.

FEATURES

- All brass conforms to AWWA Standard C800 (ASTM B-62 and ASTM B-584, UNS NO C83600 - 85-5-5-5)
- Padlock Wing for locking valve in closed position.
- Valve is non-directional and is watertight with flow in either direction.
- Ends are integral or secured with adhesive to prevent unintentional disassembly.
- Hole for attaching handle is provided in the tee-head.
- 300 PSI working pressure.

Optional full 360° tee-head rotation. Add "R" to end of part number.

The Ford Meter Box Company considers the information in this submittal form to be correct at the time of publication. Item and option availability, including specifications, are subject to change without notice. Please verify that your product information is current.



The Ford Meter Box Company, Inc.

P.O. Box 443, Wabash, Indiana U.S.A. 46992-0443

Phone: 260-563-3171 / Fax: 800-826-3487

Overseas Fax: 260-563-0167

<http://www.fordmeterbox.com>

06/18/08

Submitted By: