

SUBMITTAL INFORMATION

Ball Valve Curb Stop - (BRW41-xxxW style)

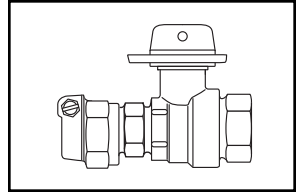

RECLAIMED WATER TEE-HEAD

PACK JOINT FOR COPPER OR PLASTIC TUBING (CTS) INLET BY FEMALE IRON PIPE THREAD OUTLET

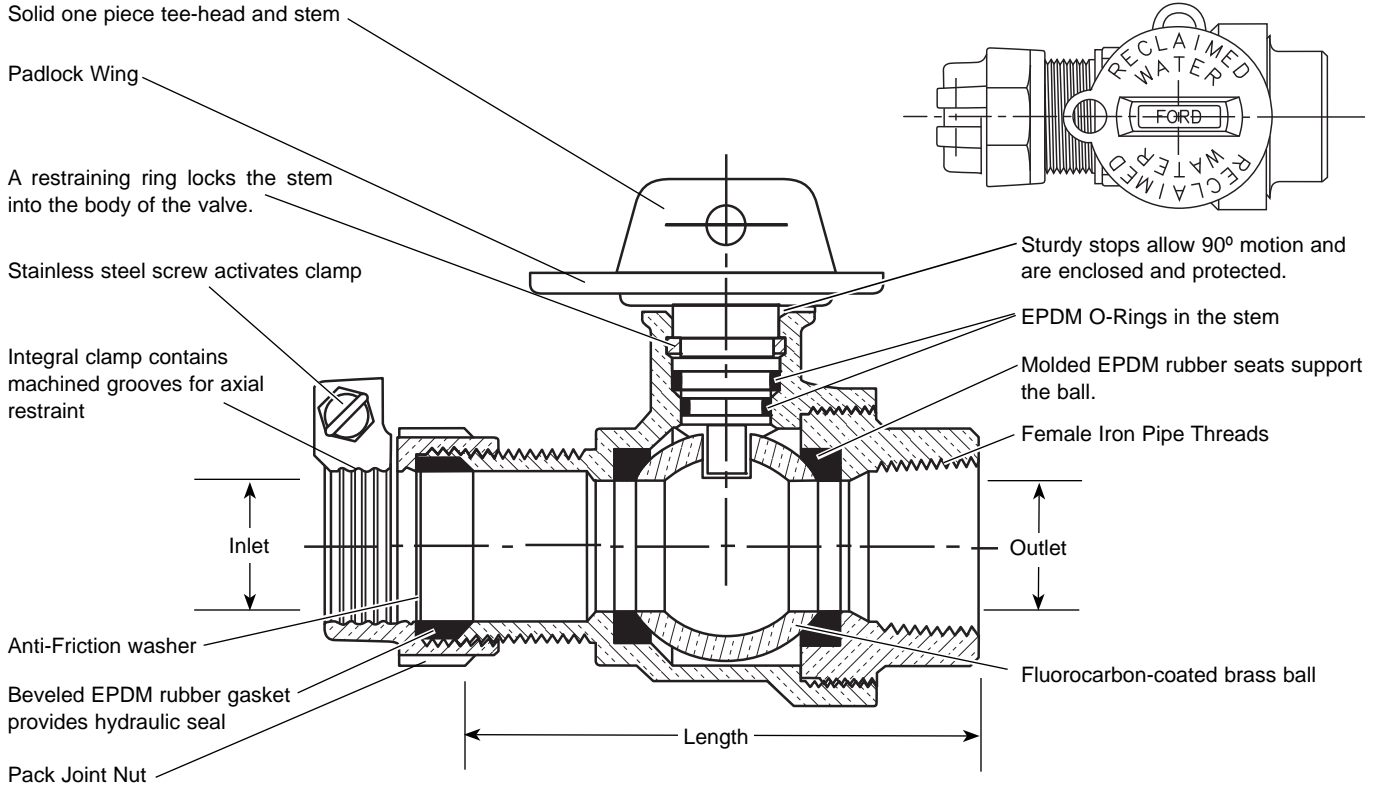

VALVE SIZE	INLET SIZE	OUTLET SIZE	LENGTH	APPROX. WT. LBS	PART NUMBER	✓ SUBMITTED ITEM(S)
3/4"	3/4"	3/4"	3-3/8"	2.1	BRW41-333W	
3/4"	1"	1"	3-9/16"	2.6	BRW41-344W	
1"	1"	1"	3-7/8"	3.0	BRW41-444W	

Note: Ford recommends using insert stiffeners with plastic pipe or tubing.

FEATURES

- All brass conforms to AWWA Standard C800 (ASTM B-62 and ASTM B-584, UNS NO C83600 - 85-5-5-5)
- Valve is non-directional and is watertight with flow in either direction.
- Ends are integral or secured with adhesive to prevent unintentional disassembly.
- Hole for attaching curb box rod or handle is provided in tee-head.
- 300 PSI working pressure.

The Ford Meter Box Company considers the information in this submittal form to be correct at the time of publication. Item and option availability, including specifications, are subject to change without notice. Please verify that your product information is current.



The Ford Meter Box Company, Inc.

P.O. Box 443, Wabash, Indiana U.S.A. 46992-0443

Phone: 260-563-3171 / Fax: 800-826-3487

Overseas Fax: 260-563-0167

<http://www.fordmeterbox.com>

05/31/07

Submitted By: