

# SUBMITTAL INFORMATION

## Brass Bushing - (C18-xx Style)

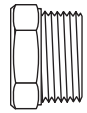

### FEMALE IRON PIPE THREAD TO MALE IRON PIPE THREAD

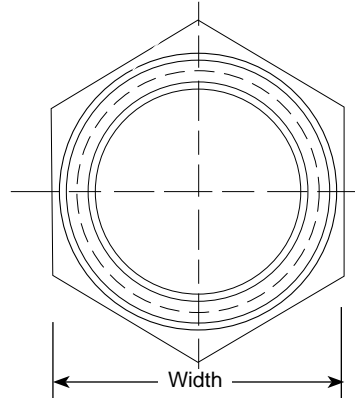
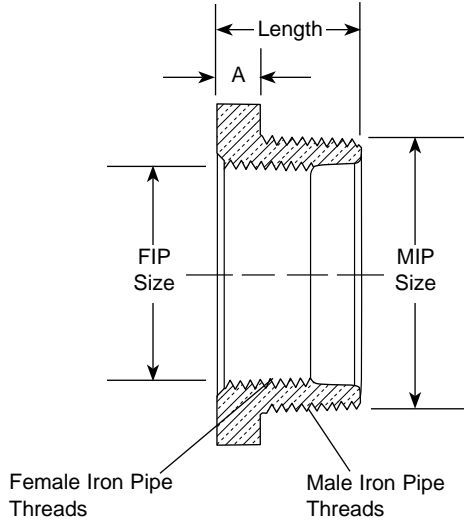

FIP SIZE	MIP SIZE	LENGTH	WIDTH	WRENCH FLAT HEIGHT (A)	APPROX. WT. LBS.	CATALOG NUMBER	✓SUBMITTED ITEM(S)
1/2"	3/4"	1"	1-1/8"	3/16"	0.1	▼ C18-13	
1/2"	1"	15/16"	1-3/8"	1/4"	0.3	▼ C18-14	
3/4"	1"	15/16"	1-3/8"	1/4"	0.2	▼ C18-34	
3/4"	1-1/4"	1-5/16"	1-1/4"	3/8"	0.5	▼▼ C18-35	
3/4"	1-1/2"	1-1/2"	2-1/8"	7/16"	0.9	▼▼ C18-36	
3/4"	2"	1-5/16"	1-5/8"	5/16"	0.8	▼▼ C18-37	
1"	3/4"	1-5/8"	1-1/2"	5/8"	0.4	▼ C18-43	
1"	1-1/4"	1-3/16"	1-1/4"	5/16"	0.4	▼▼ C18-45	
1"	1-1/2"	1-1/2"	2-1/8"	7/16"	0.9	▼▼ C18-46	
1"	2"	1-5/16"	1-1/8"	5/16"	0.7	▼▼ C18-47	
1-1/4"	1"	2"	1-15/16"	7/8"	0.7	▼▼ C18-54	
1-1/4"	1-1/2"	1-1/2"	2-1/8"	3/8"	0.5	▼▼ C18-56	
1-1/4"	2"	1-11/16"	2-1/2"	7/16"	1.4	▼▼ C18-57	
1-1/2"	2"	1-1/4"	2-1/2"	3/8"	0.8	▼▼ C18-67	
2"	2-1/2"	1-7/8"	3-1/8"	1/2"	1.4	C18-78	

▼ UL Classified to ANSI/NSF Standard 61.

▼▼ Add "-K" to end of catalog number for item to be UL classified to ANSI/NSF Standard 61.

### FEATURES

- All brass conforms to AWWA Standard C800 (ASTM B-62 and ASTM B-584, UNS NO C83600 - 85-5-5-5)
- Body design provides wrench flats to facilitate installation.

The Ford Meter Box Company considers the information in this submittal form to be correct at the time of publication. Item and option availability, including specifications, are subject to change without notice. Please verify that your product information is current.



**The Ford Meter Box Company, Inc.**

P.O. Box 443, Wabash, Indiana U.S.A. 46992-0443

Phone: 260-563-3171 / Fax: 800-826-3487

Overseas Fax: 260-563-0167

<http://www.fordmeterbox.com>

03/07/05

Submitted By: