

SUBMITTAL INFORMATION

Expansion Connection - (EC-xW style)

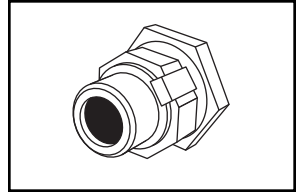

WRENCH TYPE

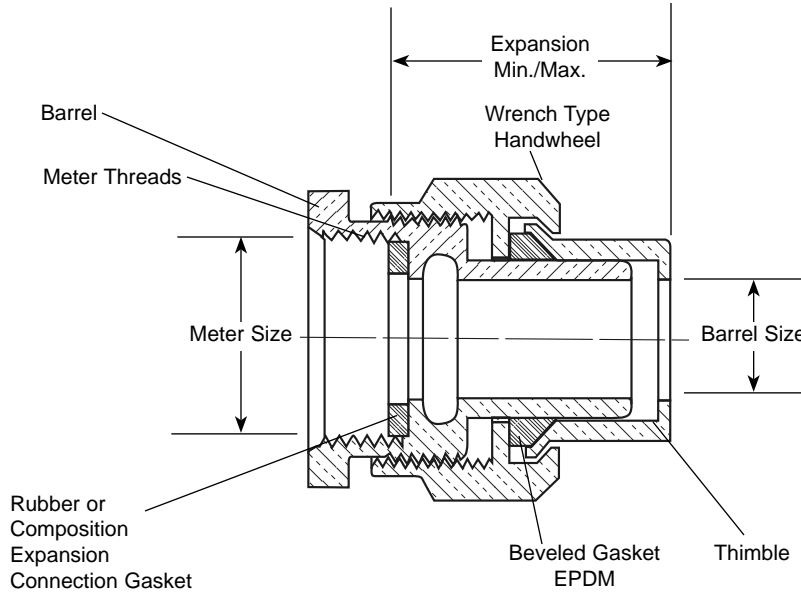

METER SIZE	BARREL SIZE	EXPANSION		APPROX. WT. LBS.	CATALOG NUMBER	✓ SUBMITTED ITEM(S)
		MIN.	MAX.			
5/8"	19/32"	1-7/16"	1-3/4"	0.6	▼ EC-1W	
5/8"x3/4" & 3/4"	3/4"	1-5/8"	2"	0.8	▼ EC-23W	

▼ UL Classified to ANSI/NSF Standard 61.



FEATURES

- All brass conforms to AWWA Standard C800 (ASTM B-62 and ASTM B-584, UNS NO C83600 - 85-5-5-5)
- Expansion Connection attaches to the meter. Together, they are installed as an expandable unit.
- Enhanced security when the expansion connection is removed along with the meter.
- Thimble nose piece does not rotate after contact with the rubber yoke end gasket. No "walking out."

The Ford Meter Box Company considers the information in this submittal form to be correct at the time of publication. Item and option availability, including specifications, are subject to change without notice. Please verify that your product information is current.



The Ford Meter Box Company, Inc.

P.O. Box 443, Wabash, Indiana U.S.A. 46992-0443

Phone: 260-563-3171 / Fax: 800-826-3487

Overseas Fax: 260-563-0167

<http://www.fordmeterbox.com>

06/18/08

Submitted By: