

SUBMITTAL INFORMATION

Repair Clamps - (F1-xxx-length style)

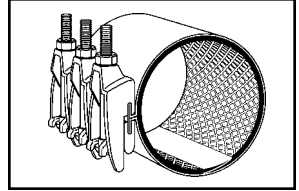

6" TO 8" STAINLESS STEEL REPAIR CLAMPS WITH DUCTILE IRON LUGS

Optional Stainless Taps

18-8 type 304 stainless steel TIG welded to band. Available with AWWA, or I.P. threads.

Band

18-8 type 304 stainless steel

Lugs

Ductile Iron per ASTM A536-84
Finish: Standard Shop Coat

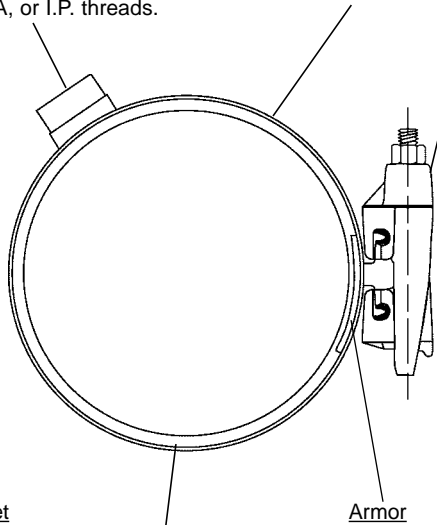

Gasket

Gridded Virgin SBR compounded for water service, per ASTM D2000-90. Buna-N, Nitrile, is available as optional material.

Armor

18-8 type 304 heavy gauge stainless steel, mold bonded into the gasket to insure uniform compression against the pipe

Nuts and Bolts

Low alloy steel per ASTM A242-91a and AWWA C111/A21.11-95

Optional

304 Stainless Steel Bolts and Nuts

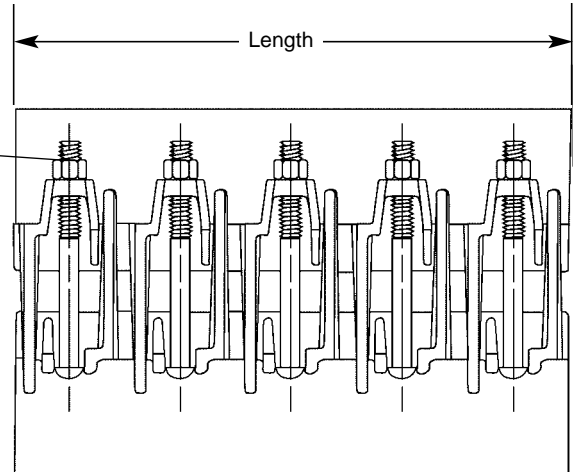

OUTLET THREAD TAP CODE

CC (AWWA) Thread		IP Thread	
THREAD	CODE NUMBER	THREAD	CODE No.
3/4" CC	-CC3	3/4" IP	-IP3
1" CC	-CC4	1" IP	-IP4
1-1/4" CC	-CC5	1-1/4" IP	-IP5
1-1/2" CC	-CC6	1-1/2" IP	-IP6
2" CC	-CC7	2" IP	-IP7

NOM. PIPE SIZE	PIPE O.D. RANGE	LENGTH AND APPROXIMATE WEIGHT (LBS.)						BOLT SIZE	BAND THICKNESS	CATALOG NUMBER F1-XXX-LENGTH	✓ SUBMITTED ITEM(S)
		7.5"	10"	12.5"	15"	20"	30"				
6"	5.95 - 6.35	12	16	20	24	32	48	5/8" x 6-1/2"	20 GA.	F1-635-	
	6.56 - 6.96									F1-696-	
	6.84 - 7.24									F1-724-	
	7.05 - 7.45									F1-745-	
	7.45 - 7.85									F1-785-	
8"	7.95 - 8.35	14	19	23	28	37	55			F1-835-	
	8.54 - 8.94									F1-894-	
	8.99 - 9.39									F1-939-	
	9.27 - 9.67									F1-967-	
	9.70 - 10.10	15	20	25	29	38	58			F1-1010-	
Number of Bolts		3	4	5	6	8	12				

FEATURES

- Drop-in bolt design allows bolts to remain attached - no loose parts to lose in the ditch.
- Also available in two- and three- section clamps for a wider range of pipe sizes and tolerances.
- Optional Outlet Taps are available for repair of service line pull-outs. Add tapping code to Catalog Number.
- All welds are fully passivated to restore corrosion resistant characteristics of stainless steel.
- Removable Lugs.

The Ford Meter Box Company considers the information in this submittal form to be correct at the time of publication. Item and option availability, including specifications, are subject to change without notice. Please verify that your product information is current.



The Ford Meter Box Company, Inc.

P.O. Box 443, Wabash, Indiana U.S.A. 46992-0443

Phone: 260-563-3171 / Fax: 800-826-3487

Overseas Fax: 260-563-0167

http://www.fordmeterbox.com

04/05/02

Submitted By: