

# SUBMITTAL INFORMATION

## Repair Clamps - (F2-xxxx-length style)

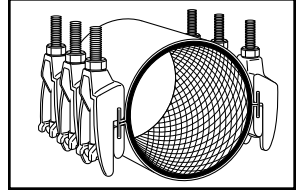

### 10" AND 12" TWO SECTION STAINLESS STEEL REPAIR CLAMPS WITH DUCTILE IRON LUGS

**Band**  
18-8 type 304 stainless steel

**Optional Stainless Taps**  
18-8 type 304 stainless steel TIG welded to band. Available with AWWA, or I.P. threads.

**Lugs**  
Ductile Iron per ASTM A536-84  
Finish: Standard Shop Coat  
Note: Lug set on one side of clamp will be closed style. Lug set on other side will consist of one open and one closed style.

**Nuts and Bolts**  
Low alloy steel per ASTM A242-91a and AWWA C111/A21.11-95

**Optional**  
304 Stainless Steel Bolts and Nuts

**Gasket**  
Gridded Virgin SBR compounded for water service, per ASTM D2000. Buna-N, Nitrile, is optional.

**Armors**  
Heavy gage 18-8 type 304 stainless steel, are mold bonded into the gasket to insure uniform compression against the pipe.

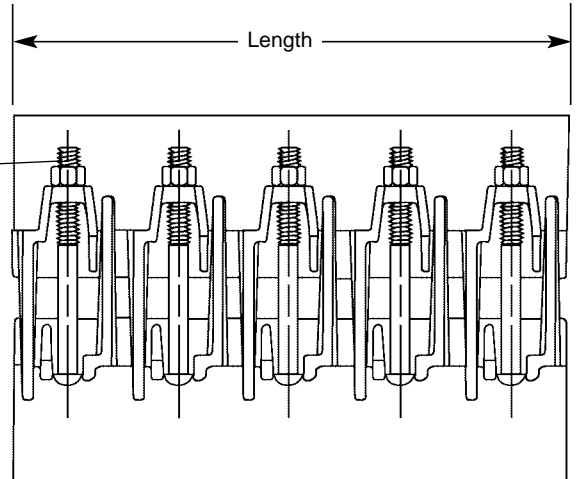

#### OUTLET THREAD TAP CODE

CC (AWWA) Thread		IP Thread	
THREAD	CODE NUMBER	THREAD	CODE No.
3/4" CC	-CC3	3/4" IP	-IP3
1" CC	-CC4	1" IP	-IP4
1-1/4" CC	-CC5	1-1/4" IP	-IP5
1-1/2" CC	-CC6	1-1/2" IP	-IP6
2" CC	-CC7	2" IP	-IP7

NOM. PIPE SIZE	PIPE O.D. RANGE	LENGTH AND APPROXIMATE WEIGHT (LBS.)						BOLT SIZE	BAND THICKNESS	CATALOG NUMBER ADD LENGTH	✓ SUBMITTED ITEM(S)
		7.5"	10"	12.5"	15"	20"	30"				
10"	10.70 - 11.50							5/8" x 6-1/2"	20 GA	F2-1150-	
	11.04 - 11.84	24	30	42	46	69	98			F2-1184-	
	11.60 - 12.40									F2-1240-	
*10" Special	11.04 - 12.24		48		71	95	144	3/4" x 8-1/2"	18 GA	F2-1224-	
12"	12.70 - 13.50							5/8" x 6-1/2"	20 GA	F2-1350-	
	13.14 - 13.94	27	30	44	47	70	100			F2-1394-	
	13.65 - 14.45									F2-1445-	
*12" Special	13.14 - 14.34		50		75	98	149	3/4" x 8-1/2"	18 GA	F2-1434-	
Number of Bolts		6	8	10	12	16	18				

#### FEATURES

- Drop-in bolt design allows bolts to remain attached - no loose parts to lose in the ditch.
- Optional Outlet Taps are available for repair of service line pull-outs. Add tap code to Catalog Number.
- All welds are fully passivated to restore corrosion resistant characteristics of stainless steel.
- Removable Lugs are standard \*(except 10" Special and 12" Special - removable lugs are optional).

The Ford Meter Box Company considers the information in this submittal form to be correct at the time of publication. Item and option availability, including specifications, are subject to change without notice. Please verify that your product information is current.



**The Ford Meter Box Company, Inc.**

P.O. Box 443, Wabash, Indiana U.S.A. 46992-0443

Phone: 260-563-3171 / Fax: 800-826-3487

Overseas Fax: 260-563-0167

<http://www.fordmeterbox.com>

06/19/02

Submitted By: