

# SUBMITTAL INFORMATION

## Iron Service Saddles for C900 PVC - (FC202-xxx-xxx style)

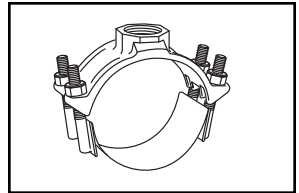

### EPOXY COATED DOUBLE BAND IRON SERVICE SADDLES FOR C900 PVC PIPE

Finish: Approximately  
12 mils of fusion epoxy  
coating

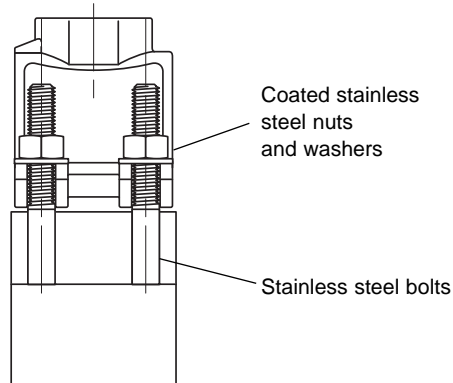
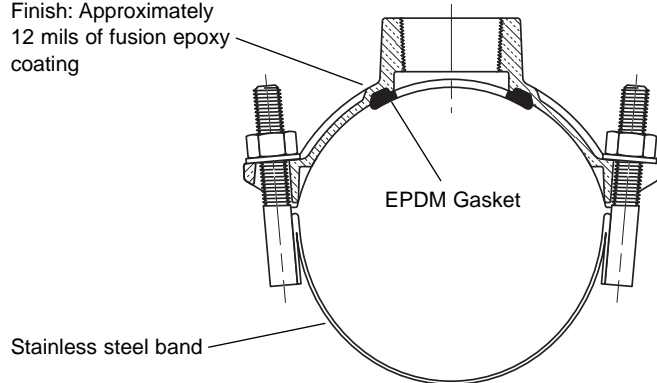

NOM. PIPE SIZE	O.D. RANGE	APPROX. WT. LBS.	CATALOG NUMBER	✓ SUBMITTED ITEM(S)
4"	4.80	5.4	▼ FC202-480-Tap	
6"	6.90	6.5	▼ FC202-690-Tap	
8"	9.05	7.4	▼ FC202-905-Tap	
10"	11.10	9.8	▼ FC202-1110-Tap	
12"	13.20	11.5	▼ FC202-1320-Tap	
14"	15.30	13.7	▼ FC202-1530-Tap	
16"	17.40	14.1	▼ FC202-1740-Tap	
18"	19.50	14.5	▼ FC202-1950-Tap	
20"	21.60	14.9	▼ FC202-2160-Tap	
24"	25.80	16	▼ FC202-2580-Tap	
30"	32.00	17	▼ FC202-3200-Tap	

▼ UL Classified to ANSI/NSF Standard 61.

#### OUTLET TAP CODE

CC (AWWA) THREAD		
THREAD	CODE NUMBER	✓ SUBMITTED ITEM(S)
3/4" CC	CC3	
1" CC	CC4	
1-1/4" CC	CC5	
1-1/2" CC	CC6	
2" CC	CC7	
IP THREAD		
THREAD	CODE NUMBER	✓ SUBMITTED ITEM(S)
3/4" IP	IP3	
1" IP	IP4	
1-1/4" IP	IP5	
1-1/2" IP	IP6	
2" IP	IP7	
2-1/2" IP	IP8	

### FEATURES

- Body made of high strength ductile iron per ASTM A536
- Double Wide Band and 5/8" UNC threaded bolts of 18-8 type 304 stainless steel.
- Gasket is EPDM rubber, ASTM-D2000
- Finish on saddle body is fusion bonded epoxy coat approximately 12 mils thick.

The Ford Meter Box Company considers the information in this submittal form to be correct at the time of publication. Item and option availability, including specifications, are subject to change without notice. Please verify that your product information is current.



#### The Ford Meter Box Company, Inc.

P.O. Box 443, Wabash, Indiana U.S.A. 46992-0443

Phone: 260-563-3171 / Fax: 800-826-3487

Overseas Fax: 260-563-0167

<http://www.fordmeterbox.com>

11/29/07

Submitted By: