

SUBMITTAL INFORMATION

Fabricated Transition Coupling - (FC23-xxx-xxx-xxR style)

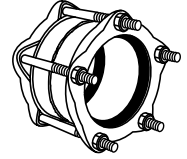

4" - COUPLINGS FOR JOINING PLAIN END PIPES WITH DIFFERENT O.D.'S

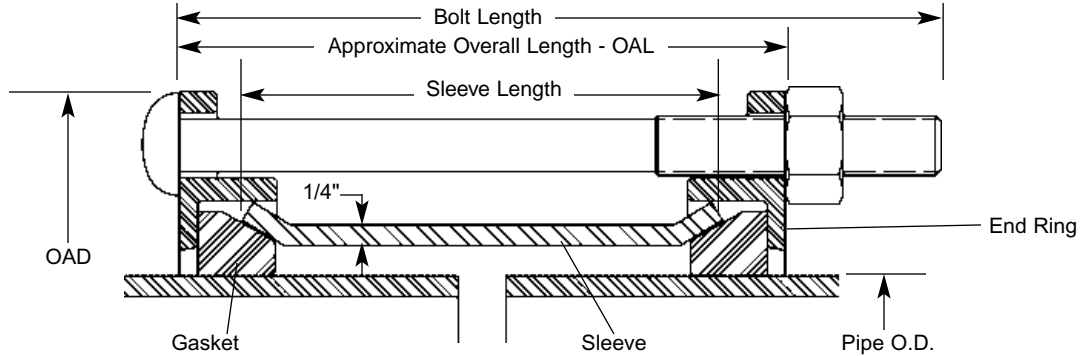

NOM. PIPE SIZE	GASKET RANGE		CENTER SLEEVE LENGTH	APPROX. OAL	BOLTS			OAD	APPROX. WT. LBS.	CATALOG NUMBER	SUBMITTED ITEM(S)				
	1ST END	2ND END			No.	DIA.	LENGTH								
4"	4.00	4.00	5"	6-1/8"	3	5/8"	9"	8-7/8"	19	FC23-400-400-05R					
			7"	8-1/8"			10-1/2"		23	FC23-400-400-07R					
			10"	11-1/8"			13-1/2"		30	FC23-400-400-10R					
		4.50	5"	6-1/8"			9"		19	FC23-400-450-05R					
			7"	8-1/8"			10-1/2"		23	FC23-400-450-07R					
			10"	11-1/8"			13-1/2"		30	FC23-400-450-10R					
		4.80-5.14	5"	6-1/8"			9"		19	FC23-400-514-05R					
			7"	8-1/8"			10-1/2"		23	FC23-400-514-07R					
			10"	11-1/8"			13-1/2"		30	FC23-400-514-10R					
		5.15-5.57	5"	6-1/8"			9"		19	FC23-400-557-05R					
			7"	8-1/8"			10-1/2"		23	FC23-400-557-07R					
			10"	11-1/8"			13-1/2"		30	FC23-400-557-10R					
	4.50	4.50	5"	6-1/8"	3	5/8"	9"	8-7/8"	19	FC23-450-450-05R					
			7"	8-1/8"			10-1/2"		23	FC23-450-450-07R					
			10"	11-1/8"			13-1/2"		30	FC23-450-450-10R					
		4.80-5.14	5"	6-1/8"			9"		19	FC23-450-514-05R					
			7"	8-1/8"			10-1/2"		23	FC23-450-514-07R					
			10"	11-1/8"			13-1/2"		30	FC23-450-514-10R					
		5.15-5.57	5"	6-1/8"			9"		19	FC23-450-557-05R					
			7"	8-1/8"			10-1/2"		23	FC23-450-557-07R					
			10"	11-1/8"			13-1/2"		30	FC23-450-557-10R					
		4.80-5.14	4.80-5.14	5"			6-1/8"		3	5/8"	9"	8-7/8"	19	FC23-514-514-05R	
				7"			8-1/8"				10-1/2"		23	FC23-514-514-07R	
				10"			11-1/8"				13-1/2"		30	FC23-514-514-10R	
5.15-5.57	5"		6-1/8"	9"	19	FC23-514-557-05R									
	7"		8-1/8"	10-1/2"	23	FC23-514-557-07R									
	10"		11-1/8"	13-1/2"	30	FC23-514-557-10R									
5.15-5.57	5.15-5.57	5"	6-1/8"	3	5/8"	9"	8-7/8"	19	FC23-557-557-05R						
		7"	8-1/8"			10-1/2"		23	FC23-557-557-07R						
		10"	11-1/8"			13-1/2"		30	FC23-557-557-10R						

Note: Flexible Couplings do not restrain axial forces on piping.

FEATURES

- Sleeve: ASTM A36 Carbon Steel
- Gasket: SBR Molded Rubber: embossed with size and end ring color code. Optional Buna-N or EPDM
- Bolts & Nuts: High Strength Low Alloy Steel per ASTM A242 & AWWA C-111. Optional: Types 304 & 316 Stainless or Electro Galvanized.
- End Ring: Ductile Iron per ASTM A536. Color coded to match gasket.
- Finish: Black Shop Coat with color coded end rings. Optional Fusion Bonded Epoxy.
- 200 PSI - Rated working pressure

The Ford Meter Box Company considers the information in this submittal form to be correct at the time of publication. Item and option availability, including specifications, are subject to change without notice. Please verify that your product information is current.



The Ford Meter Box Company, Inc.

P.O. Box 443, Wabash, Indiana U.S.A. 46992-0443

Phone: 260-563-3171 / Fax: 800-826-3487

Overseas Fax: 260-563-0167

<http://www.fordmeterbox.com>

07/24/02

Submitted By: