

SUBMITTAL INFORMATION

Ductile Iron Wide Range Transition Coupling - (FC2W-xx-L12 style)

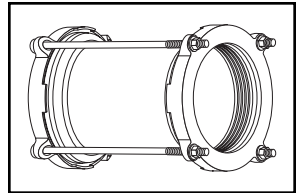

4" - 12" STYLE FC2W-L12 COUPLINGS FOR JOINING PIPES WITH DIFFERENT O.D.'S

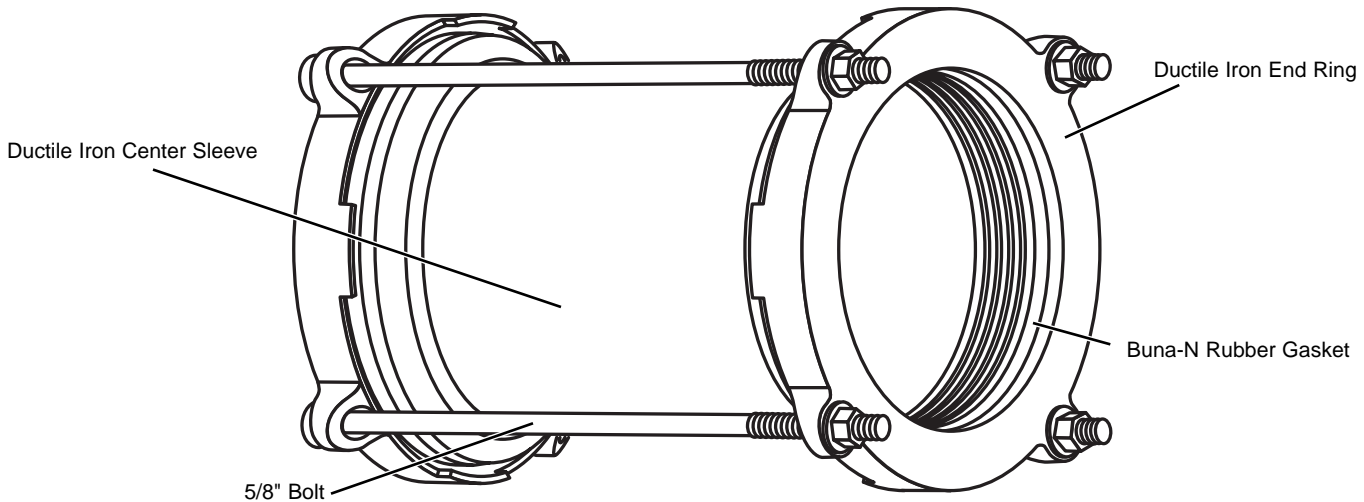

NOMINAL PIPE SIZE	RANGE (INCHES)	RANGE (MM)	BOLT DIAMETER	NUMBER OF BOLTS	SLEEVE LENGTH	APPROX. WT. LBS	PART NUMBER	✓ SUBMITTED ITEM(S)
4"	3.96 - 5.60	100.58 - 142.2	5/8"	4	12"	45	FC2W-4-L12	
6"	6.23 - 7.60	158.2 - 193.0	5/8"	4	12"	56	FC2W-6-L12	
8"	8.40 - 9.75	213.3 - 247.6	5/8"	4	12"	69	FC2W-8-L12	
10"	10.75 - 12.12	273.0 - 307.8	5/8"	6	12"	90	FC2W-10-L12	
12"	12.75 - 14.38	323.8 - 365.25	5/8"	6	12"	109	FC2W-12-L12	

FEATURES

- Center Sleeve: Ductile Iron per ASTM A536 (65-45-12)
- End Rings: Ductile Iron per ASTM A536 (65-45-12)
- Bolts and nuts: High strength low alloy steel per ASTM A242 and AWWA C111
Bolts have an oval neck beneath the head, which rests within the end ring to prevent bolts from rotating while tightening.
Optional stainless steel bolts and nuts are available
- Coating: Black, fusion bonded epoxy applied per AWWA C213
- Gasket: Buna-N rubber per ASTM D2000
- 250 psi rated working water pressure

The Ford Meter Box Company considers the information in this submittal form to be correct at the time of publication. Item and option availability, including specifications, are subject to change without notice. Please verify that your product information is current.



The Ford Meter Box Company, Inc.

P.O. Box 443, Wabash, Indiana U.S.A. 46992-0443

Phone: 260-563-3171 / Fax: 800-826-3487

Overseas Fax: 260-563-0167

<http://www.fordmeterbox.com>

3/10/05

Submitted By: