

# SUBMITTAL INFORMATION

## Repair Clamps - (FS1-xxx style)

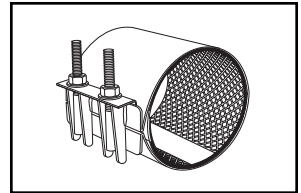

### 2" TO 4" ALL STAINLESS STEEL CIRCLE REPAIR CLAMPS

**Optional Stainless Taps**  
ASTM A240 type 304 stainless steel tig welded to band. Available with AWWA or I.P. threads.

**Band**  
ASTM A240 type 304 stainless steel

**Lifter Bar**  
ASTM A240 type 304 heavy gauge stainless steel

**Sidebar**  
ASTM A240 type 304 heavy gauge stainless steel

**Lug**  
ASTM A240 type 304 heavy gauge stainless steel

**Armor**  
ASTM A240 type 304 heavy gauge stainless steel, mold bonded into the gasket to ensure uniform compression against the pipe

**Gasket**  
Gridded virgin SBR compounded for water service, per ASTM D2000. Buna-N Nitrile is optional.

\* Nylatron GS is a registered trademark of the Polymer Corporation.

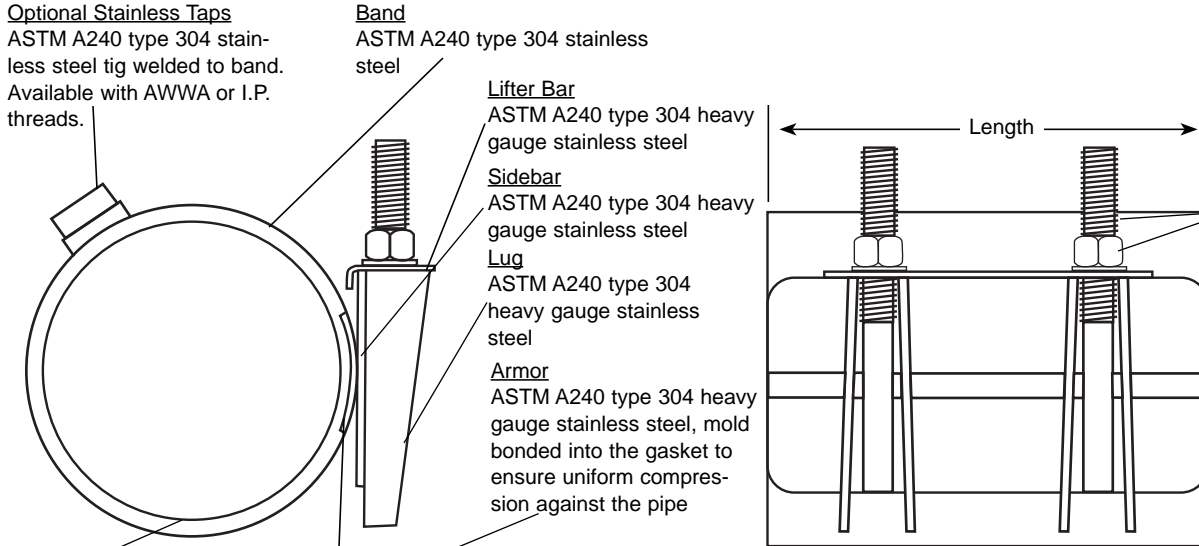

**Bolts & Nuts**  
ASTM A240 type 304 stainless steel nuts are coated to prevent galling. Special \*Nylatron GS washers are provided for added lubrication.

#### OUTLET THREAD TAP CODE

CC (AWWA) Thread			IP Thread		
THREAD	CODE NUMBER	MIN. CLAMP SZ.	THREAD	CODE NUMBER	MIN. CLAMP SZ.
3/4" CC	-CC3	2.63	3/4" IP	-IP3	2.63
1" CC	-CC4	2.63	1" IP	-IP4	2.63
1-1/4" CC	-CC5	3.70	1-1/4" IP	-IP5	3.70
1-1/2" CC	-CC6	4.25	1-1/2" IP	-IP6	3.70
2" CC	-CC7	4.73	2" IP	-IP7	4.25

NOM. PIPE SIZE	PIPE O.D. RANGE	LENGTH AND APPROXIMATE WEIGHT (LBS.)									BOLT SIZE	BAND THICKNESS	CATALOG NUMBER FS1-XXX-LENGTH	✓ SUBMITTED ITEM(S)
		6"	7.5"	10"	12.5"	15"	20"	24"	30"					
2"	2.35 - 2.63	4	4	5	5	8	n/a	n/a	n/a	1/2" 13 UNC	24 GA.	▼ FS1-263-		
2-1/4" - 2-1/2"	2.70 - 3.00	4	5	5	6	8	n/a	n/a	n/a			▼ FS1-300-		
												▼ FS1-325-		
3"	2.97 - 3.25	4	5	5	6	9	n/a	n/a	n/a			▼ FS1-370-		
	3.46 - 3.70											▼ FS1-400-		
	3.73 - 4.00											▼ FS1-425-		
3" - 4"	3.96 - 4.25	5	5	6	7	9	n/a	n/a	n/a		▼ FS1-473-			
	4.45 - 4.73										▼ FS1-514-			
4"	4.74 - 5.14	5	6	7	8	10	14	16	21		5/8" 11 UNC	24 GA.	▼ FS1-535-	
	4.95 - 5.35												▼ FS1-562-	
	5.22 - 5.62													
Number of Bolts		2	2	3	3	4	6	6	9			▼ UL Classified to ANSI/NSF Standard 61.		

#### FEATURES

- Buna-N Gasket and Conductivity Strips are available.
- Also available in two-and three- section clamps for a wider range of pipe sizes and tolerances.
- Optional Outlet Taps are available for repair of service line pull-outs. Add tapping code to Catalog Number.
- All welds are fully passivated to restore corrosion resistant characteristics of stainless steel.

The Ford Meter Box Company considers the information in this submittal form to be correct at the time of publication. Item and option availability, including specifications, are subject to change without notice. Please verify that your product information is current.



**The Ford Meter Box Company, Inc.**  
P.O. Box 443, Wabash, Indiana U.S.A. 46992-0443  
Phone: 260-563-3171 / Fax: 800-826-3487  
Overseas Fax: 260-563-0167  
<http://www.fordmeterbox.com>

08/16/05

Submitted By: \_\_\_\_\_