

SUBMITTAL INFORMATION

Angle Check Valve - (HA94-xxx-G style)

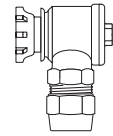

METER YOKE NOSE INLET BY GRIP JOINT FOR COPPER OR PLASTIC TUBING (CTS) OUTLET

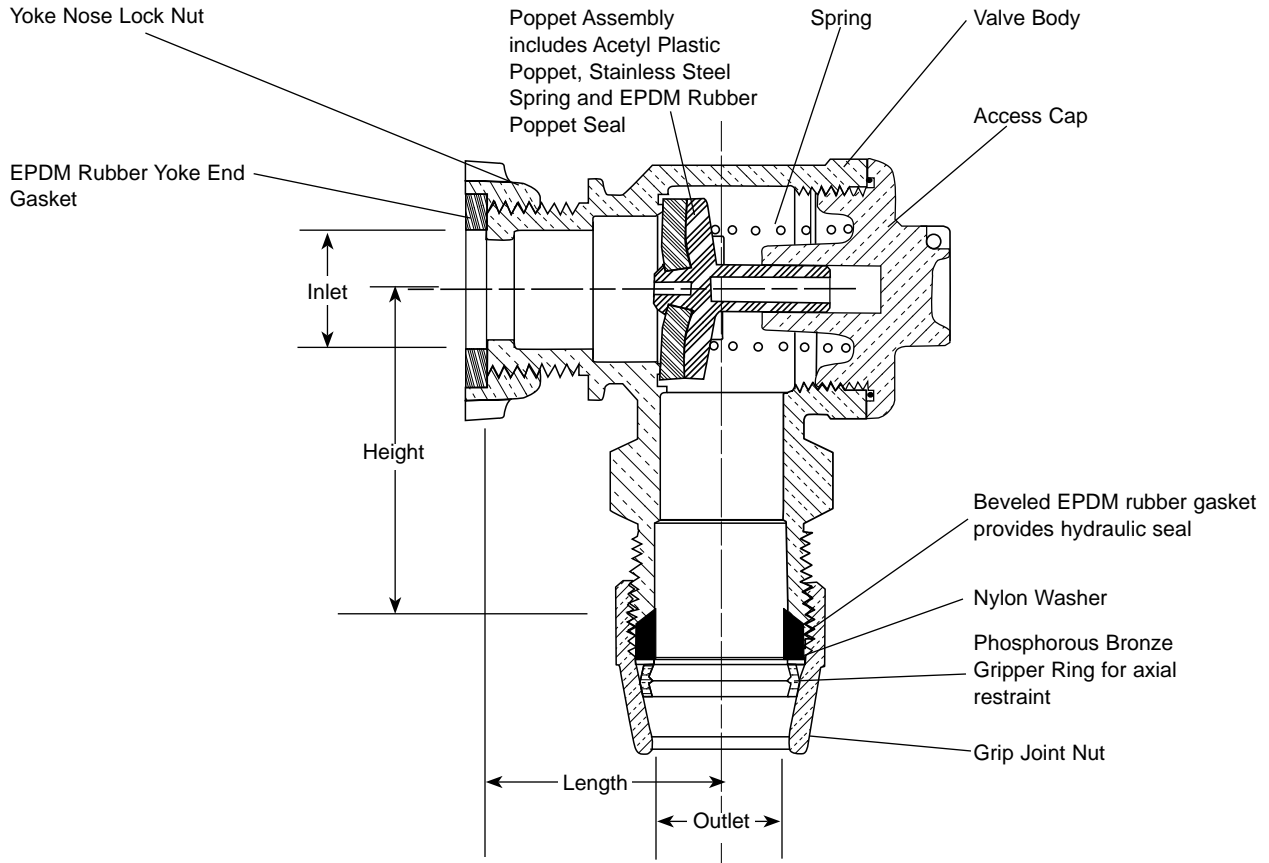

VALVE SIZE	METER SIZE	OUTLET SIZE	LENGTH	HEIGHT	APPROX. WT. LBS	CATALOG NUMBER	✓ SUBMITTED ITEM(S)
3/4"	5/8"	3/4"	1-5/8"	2-3/8"	1.6	HA94-313-G	
3/4"	5/8"x3/4" & 3/4"	3/4"	1-5/8"	2-3/8"	1.6	HA94-323-G	

Note: Ford recommends using insert stiffeners with plastic pipe or tubing.
 Drain/Test Valve available - add "D" to catalog number

FEATURES

- All brass conforms to AWWA Standard C800 (ASTM B-62 and ASTM B-584, UNS NO C83600 - 85-5-5-5).
- In-Line accessible for quick inspection and replacement of internal working parts without removing the valve from the service line. Replacement kits are available.
- 175 PSI maximum working water pressure.

The Ford Meter Box Company considers the information in this submittal form to be correct at the time of publication. Item and option availability, including specifications, are subject to change without notice. Please verify that your product information is current.



The Ford Meter Box Company, Inc.

P.O. Box 443, Wabash, Indiana U.S.A. 46992-0443

Phone: 260-563-3171 / Fax: 800-826-3487

Overseas Fax: 260-563-0167

<http://www.fordmeterbox.com>

04/27/04

Submitted By: