

SUBMITTAL INFORMATION

Angle Cascading Dual Check Valve - (HHA32-323 style)

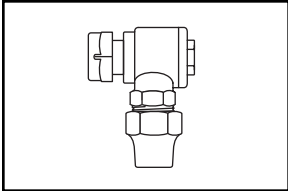

METER SWIVEL NUT INLET BY FLARE COPPER OUTLET

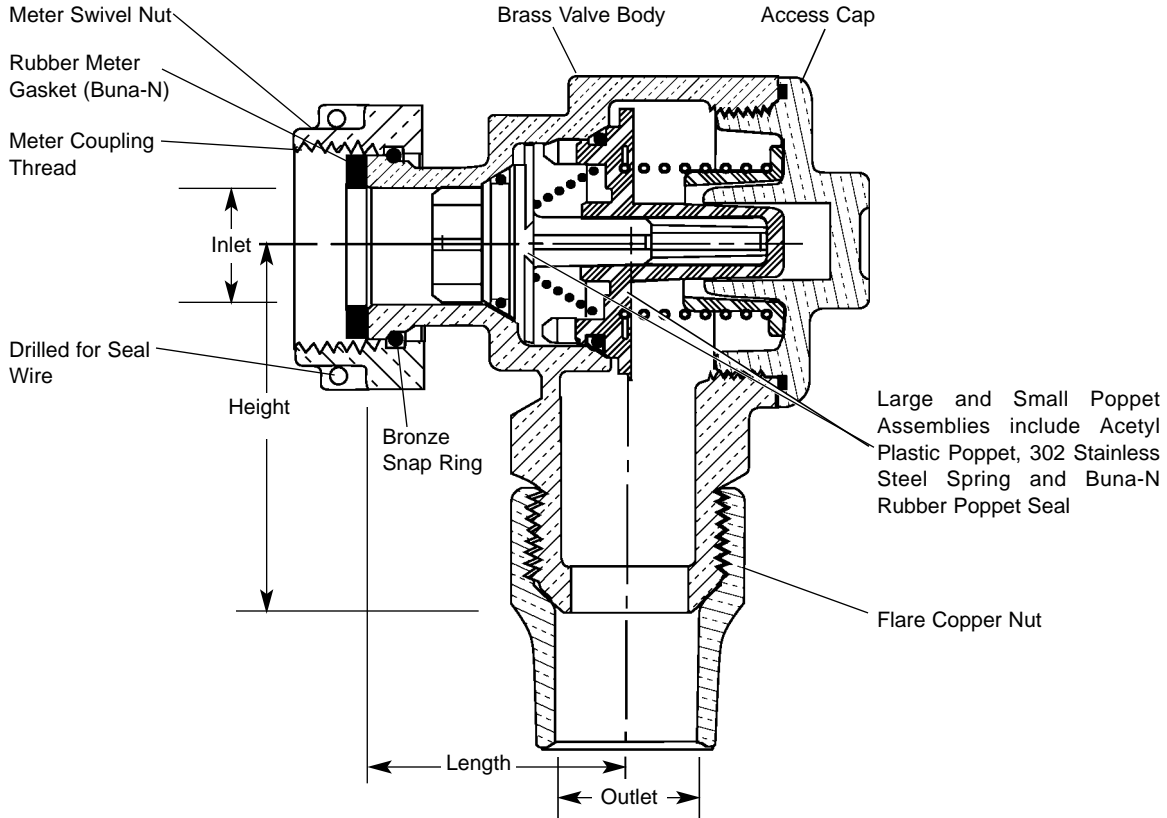

VALVE SIZE	METER INLET SIZE	OUTLET SIZE	LENGTH	HEIGHT	APPROX. WT. LBS	PART NUMBER	✓ SUBMITTED ITEM(S)
3/4"	5/8" x 3/4" & 3/4"	3/4"	1-11/16"	2-3/8"	2.2	HHA32-323	

FEATURES

- All brass conforms to AWWA Standard C800 (ASTM B-62, UNS NO C83600 - 85-5-5-5).
- ASSE 1024 Approved.
- In-Line Accessible for quick inspection and replacement of internal working parts without removing the valve from the service line. Replacement kits are available.
- 175 PSI maximum working water pressure.
- 180 degree fahrenheit maximum constant temperature.
- Conforms to AWWA C700 for Meter Threads.

The Ford Meter Box Company considers the information in this submittal form to be correct at the time of publication. Item and option availability, including specifications, are subject to change without notice. Please verify that your product information is current.



The Ford Meter Box Company, Inc.

P.O. Box 443, Wabash, Indiana U.S.A. 46992-0443

Phone: 260-563-3171 / Fax: 800-826-3487

Overseas Fax: 260-563-0167

<http://www.fordmeterbox.com>

03/29/02

Submitted By: