

SUBMITTAL INFORMATION

Angle Cartridge Dual Check Valve - (HHCA92-xxx style)

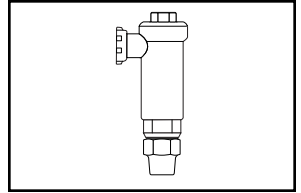

METER YOKE NOSE INLET BY FLARE COPPER OUTLET

U.S. Pat. No. 5,148,828

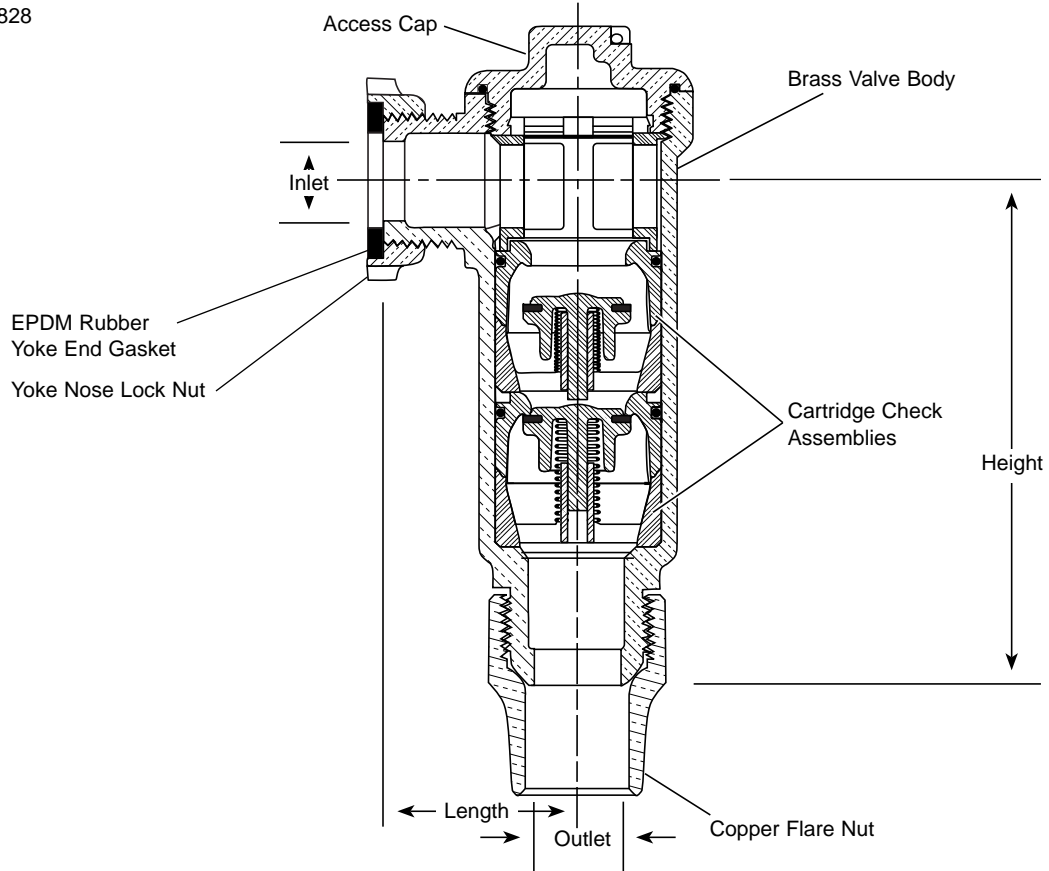

VALVE SIZE	METER SIZE	OUTLET SIZE	LENGTH	HEIGHT	APPROX. WT. LBS	CATALOG NUMBER	✓ SUBMITTED ITEM(S)
3/4"	5/8"	3/4"	1-5/8"	4-3/4"	2.2	▼▼ HHCA92-313	
3/4"	5/8"x3/4" & 3/4"	3/4"	1-5/8"	4-3/4"	2.2	▼▼ HHCA92-323	
1"	5/8"x3/4" & 3/4"	1"	2-3/16"	4-13/16"	3.9	▼▼ HHCA92-424	
1"	1"	1"	2-3/16"	4-13/16"	3.9	▼▼ HHCA92-444	

Drain/Test Valve available - add "D" to catalog number

▼▼ Add "-K" to end of catalog number for item to be UL classified to ANSI/NSF Standard 61.

FEATURES

- All brass conforms to AWWA Standard C800 (ASTM B-62 and ASTM B-584, UNS NO C83600 - 85-5-5-5).
- ASSE 1024 approved.
- In-line accessible for quick inspection and replacement of internal working parts without removing the valve from the service line. Replacement kits are available.
- 175 PSI maximum working water pressure.
- 180 degree Fahrenheit maximum constant temperature.

The Ford Meter Box Company considers the information in this submittal form to be correct at the time of publication. Item and option availability, including specifications, are subject to change without notice. Please verify that your product information is current.



The Ford Meter Box Company, Inc.

P.O. Box 443, Wabash, Indiana U.S.A. 46992-0443

Phone: 260-563-3171 / Fax: 800-826-3487

Overseas Fax: 260-563-0167

<http://www.fordmeterbox.com>

01/03/08

Submitted By: