

# SUBMITTAL INFORMATION

## Yoke Ell Couplings - (SI-L94-13-AWT-G style)

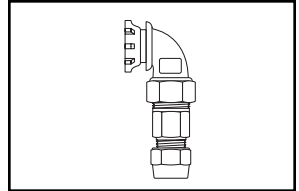

**INSULATED - METER YOKE NOSE BY GRIP JOINT NUT FOR COPPER OR PLASTIC TUBING (CTS)**

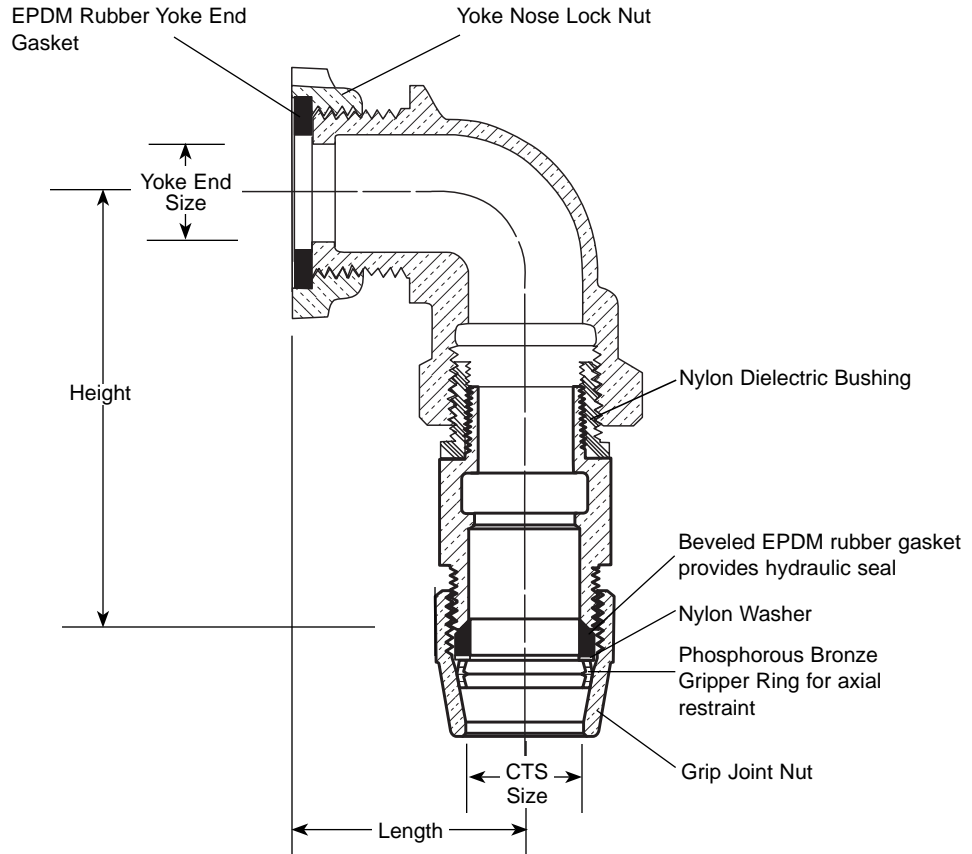

YOKE END SIZE	CTS SIZE	LENGTH	HEIGHT	APPROX. WT. LBS	PART NUMBER	✓ SUBMITTED ITEM(S)
5/8"	3/4"	1-1/2"	3-3/4"	1.4	SI-L94-13-AWT-G	

**Note:** Ford recommends using insert stiffeners with plastic pipe or tubing.

### FEATURES

- All brass conforms to AWWA Standard C800 (ASTM B-62 and ASTM B-584, UNS NO C83600 - 85-5-5-5).
- Body design provides larger, more rugged wrench flats for proper installation.
- Yoke Ell couplings may be used on either end of the yoke.

The Ford Meter Box Company considers the information in this submittal form to be correct at the time of publication. Item and option availability, including specifications, are subject to change without notice. Please verify that your product information is current.



**The Ford Meter Box Company, Inc.**

P.O. Box 443, Wabash, Indiana U.S.A. 46992-0443

Phone: 260-563-3171 / Fax: 800-826-3487

Overseas Fax: 260-563-0167

<http://www.fordmeterbox.com>

09/15/05

Submitted By: