

# SUBMITTAL INFORMATION

## Straight Ball Valve Branch Assembly - (UVBS49-42W style)

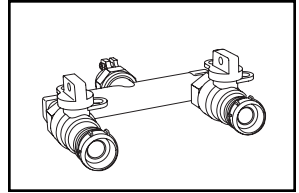

**PACK JOINT FOR COPPER OR PLASTIC TUBING (CTS) INLET BY TWO METER YOKE NOSE OUTLETS**

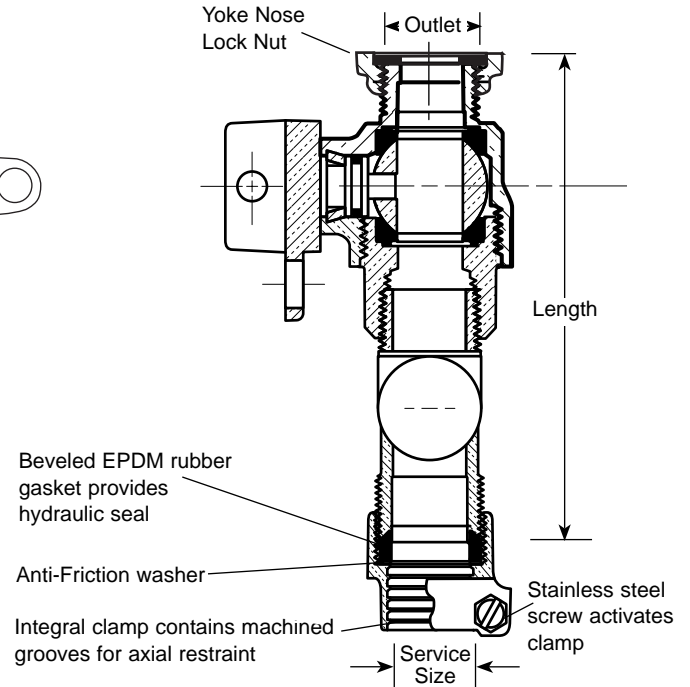
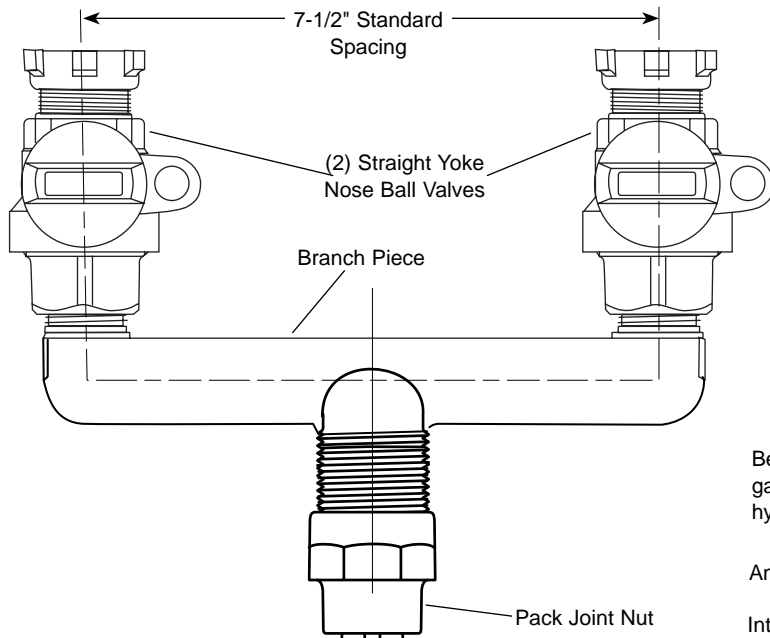

SERVICE SIZE	METER SIZE	LENGTH	APPROX. WT. LBS.	Components		Assembly	✓ SUBMITTED ITEM(S)
				BRANCH PIECE	VALVES (2)	CATALOG NUMBER	
1"	5/8" x 3/4" OR 3/4"	5-7/8"	4.2	U48-43	B91-223W	♦ UVBS49-42W	

**Note:** Ford recommends using insert stiffeners with plastic pipe and tubing.  
 ♦ Manufactured from brass components that are UL Classified to ANSI/NSF Standard 61.

### FEATURES

- All brass conforms to AWWA Standard C800 (ASTM B-62 and ASTM B-584, UNS NO C83600 - 85-5-5-5)
- All Branch Valve Assemblies have Padlock Wings.
- Meter gaskets are furnished with all Branch Valve Assemblies.
- Meets 300 PSI pressure requirements of AWWA Standard C800.

The Ford Meter Box Company considers the information in this submittal form to be correct at the time of publication. Item and option availability, including specifications, are subject to change without notice. Please verify that your product information is current.



### The Ford Meter Box Company, Inc.

P.O. Box 443, Wabash, Indiana U.S.A. 46992-0443

Phone: 260-563-3171 / Fax: 800-826-3487

Overseas Fax: 260-563-0167

<http://www.fordmeterbox.com>

12/20/05

Submitted By: