

SUBMITTAL INFORMATION

70 Series Coppersetter - (VHH77-xxHBHC-11-77 style)

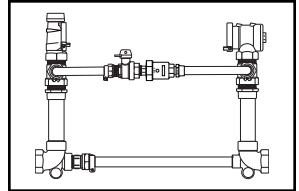

**FLANGED ANGLE KEY VALVE BY FLANGED DUAL CHECK VALVE
WITH DUAL CHECK VALVE IN HIGH BY-PASS (2" METER)**

FEMALE IRON PIPE THREAD INLET AND OUTLET

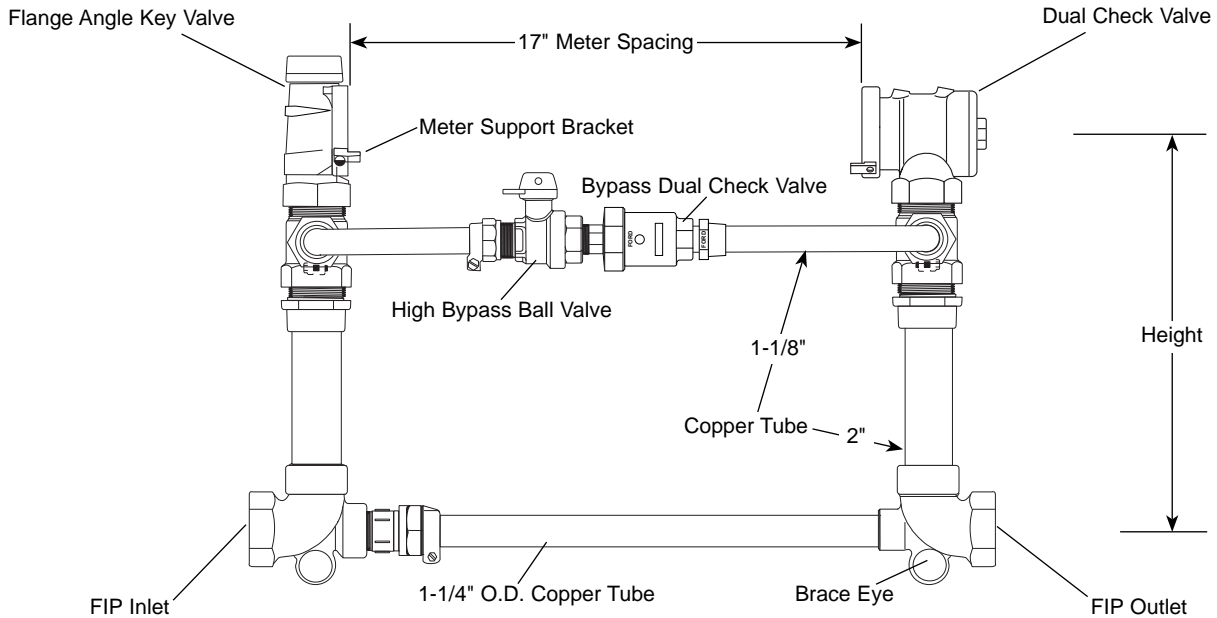

SERVICE LINE CONNECTION		HEIGHT	APPROX. Wt. LBS.	CATALOG NUMBER	✓ SUBMITTED ITEM(S)
FIP INLET	FIP OUTLET				
2"	2"	12"	37	VHH77-12HBHC-11-77	
		15"	38	VHH77-15HBHC-11-77	
		18"	39	VHH77-18HBHC-11-77	
		21"	40	VHH77-21HBHC-11-77	
		24"	41	VHH77-24HBHC-11-77	
		27"	42	VHH77-27HBHC-11-77	

FEATURES

- All brass conforms to AWWA Standard C800 (ASTM B-62 and ASTM B-584, UNS NO C83600 - 85-5-5-5)
- Dual Check Valve is ASSE 1024 approved.
- Constructed with Type K Copper, and conforms to ASTM B-88, Copper Alloy #122.
- All Ford Meter Setters are assembled with Lead-Free Solder.
- Bracing Eyes are standard.
- Meter Support Brackets are standard.
- Padlock Wing is standard on all Angle Meter Ball Valves or Key Valves.

The Ford Meter Box Company considers the information in this submittal form to be correct at the time of publication. Item and option availability, including specifications, are subject to change without notice. Please verify that your product information is current.



The Ford Meter Box Company, Inc.

P.O. Box 443, Wabash, Indiana U.S.A. 46992-0443
 Phone: 260-563-3171 / Fax: 800-826-3487
 Overseas Fax: 260-563-0167
<http://www.fordmeterbox.com>

04/22/08

Submitted By: