

SUBMITTAL INFORMATION

Ball Valve Curb Stop - Minneapolis Pattern - (B24-333M style)

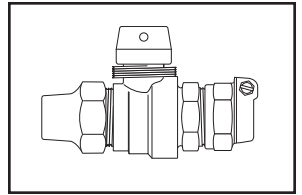

FLARE COPPER INLET BY PACK JOINT FOR COPPER OR PLASTIC TUBING (CTS) OUTLET

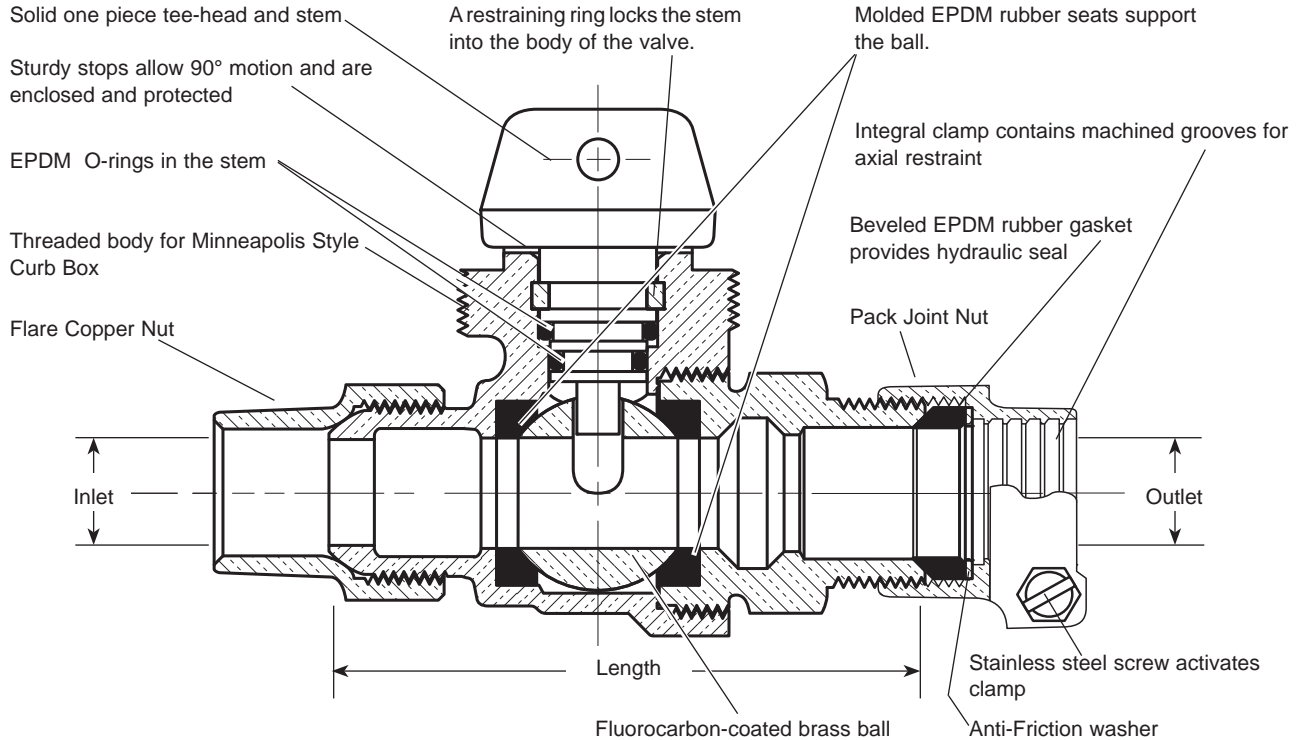

VALVE SIZE	INLET SIZE	OUTLET SIZE	LENGTH	APPROX. WT. LBS	PART NUMBER	✓ SUBMITTED ITEM(S)
3/4"	3/4"	3/4"	4-1/8"	-	▼ B24-333M	

Note: Ford recommends using insert stiffeners with plastic pipe or tubing.

▼ UL Classified to ANSI/NSF Standard 61.



FEATURES

- All brass conforms to AWWA Standard C800 (ASTM B-62 and ASTM B-584, UNS NO C83600 - 85-5-5-5)
- Valve is non-directional and is watertight with flow in either direction.
- Ends are integral or secured with adhesive to prevent unintentional disassembly.
- Hole for attaching curb box rod or handle is provided in tee-head.
- 300 PSI working pressure.

Padlock Wing option is not available on the Minneapolis Pattern Curb Stop.

Optional full 360° tee-head rotation. Add "R" to end of part number.

The Ford Meter Box Company considers the information in this submittal form to be correct at the time of publication. Item and option availability, including specifications, are subject to change without notice. Please verify that your product information is current.



The Ford Meter Box Company, Inc.

P.O. Box 443, Wabash, Indiana U.S.A. 46992-0443

Phone: 260-563-3171 / Fax: 800-826-3487

Overseas Fax: 260-563-0167

<http://www.fordmeterbox.com>

10/22/07

Submitted By: