

SUBMITTAL INFORMATION

Straight Ball Meter Valves - (B73-2xxW style)

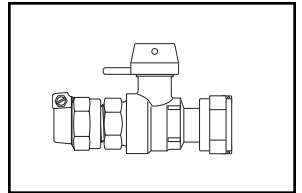

5/8" VALVES WITH PACK JOINT FOR PVC PIPE INLET BY METER SWIVEL NUT OUTLET

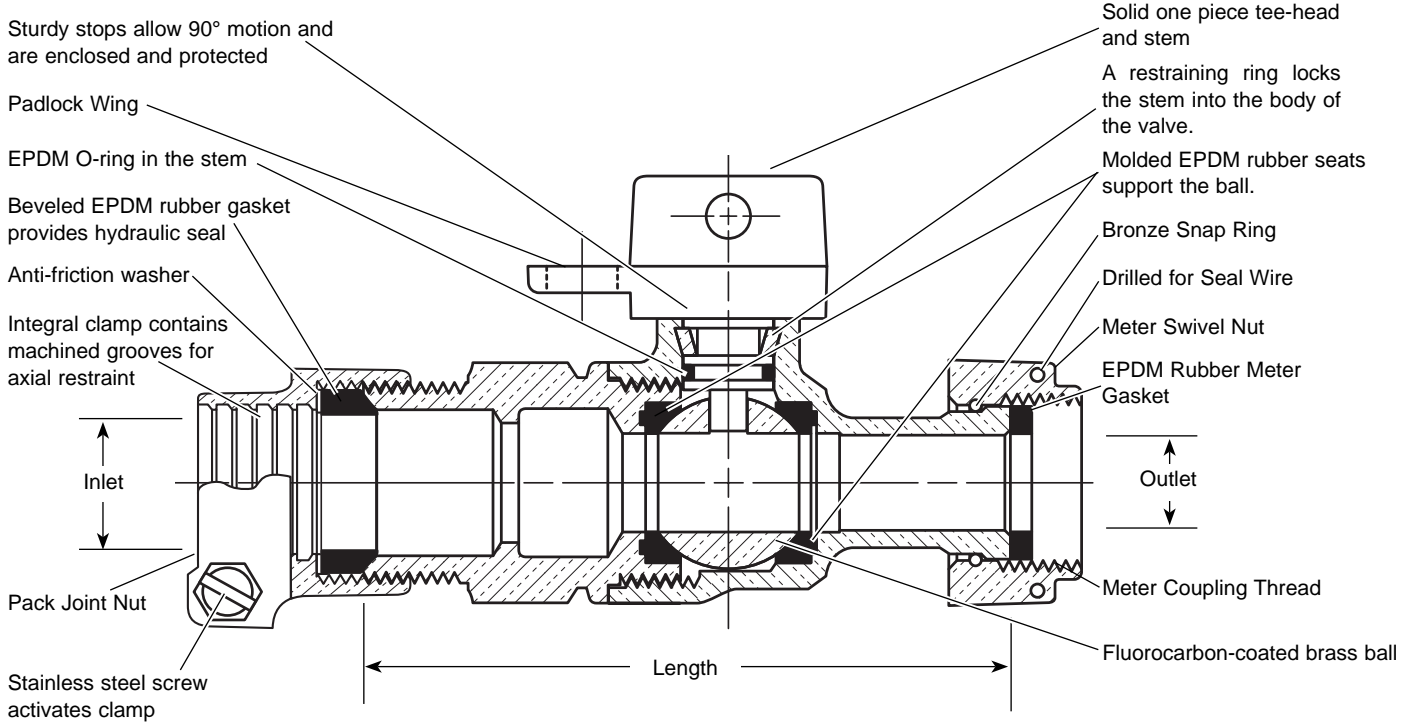

VALVE SIZE	SERVICE LINE SIZE INLET	METER SIZE OUTLET	LENGTH	APPROX. WT. LBS	PART NUMBER	✓ SUBMITTED ITEM(S)
5/8"	3/4"	5/8"	4-3/16"	1.8	▼ B73-231W	
5/8"	3/4"	5/8"x3/4" & 3/4"	4-1/8"	1.9	▼ B73-232W	

▼ UL Classified to ANSI/NSF Standard 61.

Note: Ford Pack Joints for PVC are only recommended for Schedule 40 and Schedule 80 pipe.



FEATURES

- All brass conforms to AWWA Standard C800 (ASTM B-62 and ASTM B-584, UNS NO C83600 - 85-5-5-5)
- Valve is non-directional and is watertight with flow in either direction.
- Ends are integral or secured with adhesive to prevent unintentional disassembly.
- Padlock Wing for locking valve in closed position.
- Hole for attaching handle is provided in the tee-head.
- 300 PSI working pressure.

Optional full 360° tee-head rotation. Add "R" to end of part number.

The Ford Meter Box Company considers the information in this submittal form to be correct at the time of publication. Item and option availability, including specifications, are subject to change without notice. Please verify that your product information is current.



The Ford Meter Box Company, Inc.

P.O. Box 443, Wabash, Indiana U.S.A. 46992-0443

Phone: 260-563-3171 / Fax: 800-826-3487

Overseas Fax: 260-563-0167

<http://www.fordmeterbox.com>

04/27/04

Submitted By: