

SUBMITTAL INFORMATION

Ball Valve Curb Stop - (B84-xxx-G style)

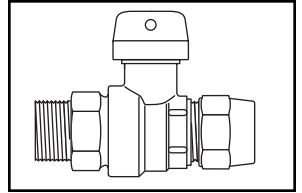

MALE IRON PIPE THREAD INLET BY GRIP JOINT FOR COPPER OR PLASTIC TUBING (CTS) OUTLET

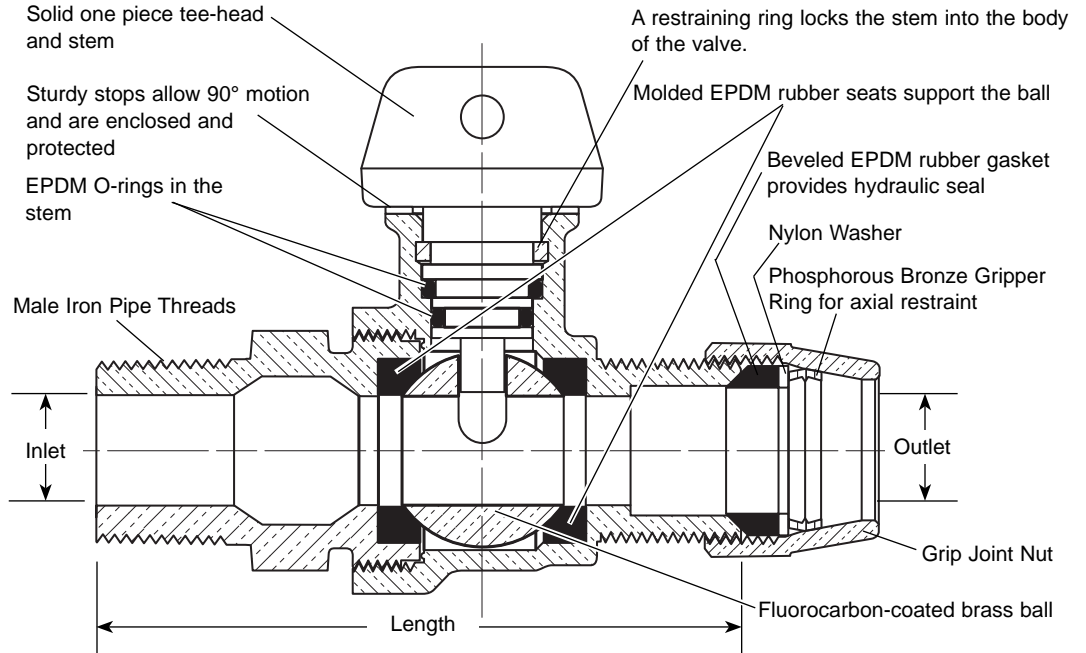
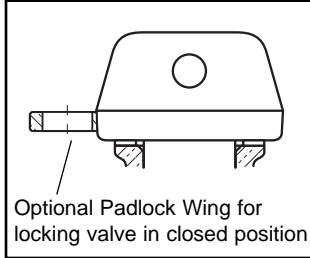

VALVE SIZE	INLET SIZE	OUTLET SIZE	LENGTH	APPROX. WT. LBS	PART NUMBER	✓ SUBMITTED ITEM(S)
3/4"	3/4"	3/4"	3-7/8"	1.9	▼ B84-333 -G	
1"	1"	1"	4-11/16"	-	▼ B84-444 -G	
1"	1-1/4"	1-1/4"	5-7/8"	4.3	▼ B84-455 -G	
2"	2"	2"	7-9/16"	-	▼▼ B84-777 -G	
2"	2-1/2"	2-1/2"	8-5/16"	-	B84-788 -G	



▼ UL Classified to ANSI/NSF Standard 61.

▼▼ Add "-K" to end of catalog number for item to be UL classified to ANSI/NSF Standard 61.

Note: Ford recommends using insert stiffeners with plastic pipe or tubing.

FEATURES

- All brass conforms to AWWA Standard C800 (ASTM B-62 and ASTM B-584, UNS NO C83600 - 85-5-5-5)
- Valve is non-directional and is watertight with flow in either direction.
- Ends are integral or secured with adhesive to prevent unintentional disassembly.
- Hole for attaching curb box rod or handle is provided in tee-head.
- 300 PSI working pressure.

Optional Padlock Wing for locking valve in closed position. Insert "W" into part number.

Optional full 360° tee-head rotation. Insert "R" into part number.

The Ford Meter Box Company considers the information in this submittal form to be correct at the time of publication. Item and option availability, including specifications, are subject to change without notice. Please verify that your product information is current.



The Ford Meter Box Company, Inc.

P.O. Box 443, Wabash, Indiana U.S.A. 46992-0443

Phone: 260-563-3171 / Fax: 800-826-3487

Overseas Fax: 260-563-0167

<http://www.fordmeterbox.com>

07/12/05

Submitted By: