

SUBMITTAL INFORMATION

Angle Ball Meter Valves - (BA23-xxxW style)

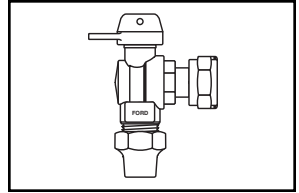

FLARE COPPER INLET BY METER SWIVEL NUT OUTLET

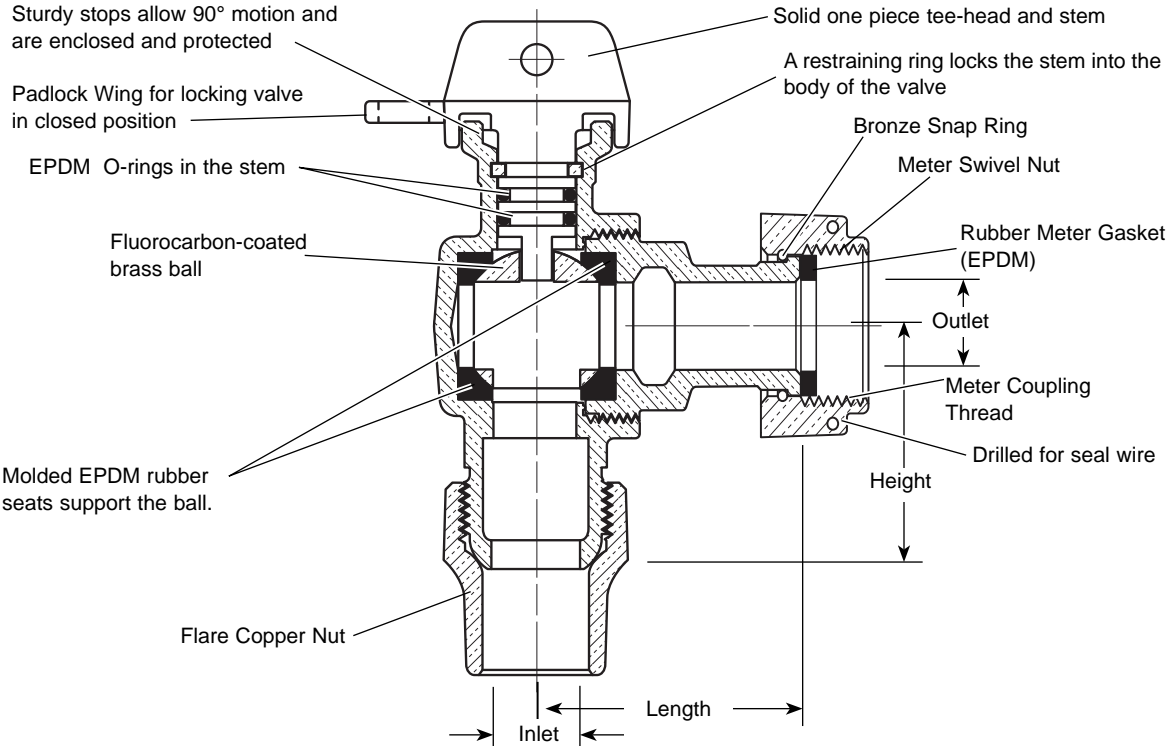

VALVE SIZE	SERVICE LINE SIZE INLET	METER SIZE OUTLET	LENGTH	HEIGHT	APPROX. Wt. Lbs	PART NUMBER	✓ SUBMITTED ITEM(S)
3/4"	3/4"	5/8"	2-1/4"	2-1/8"	2.2	▼ BA23-331W	
3/4"	3/4"	5/8"x3/4" & 3/4"	2-1/4"	2-1/8"	2.3	▼ BA23-332W	
3/4"	1"	5/8"	2-1/4"	2-1/4"	2.6	▼ BA23-341W	
3/4"	1"	5/8"x3/4" & 3/4"	2-1/4"	2-1/4"	2.7	▼ BA23-342W	
3/4"	1"	1"	2"	2-1/4"	2.8	▼ BA23-344W	
1"	1"	1"	2-11/16"	2-11/16"	3.8	▼▼ BA23-444W	

▼ UL Classified to ANSI/NSF Standard 61.

▼▼ Add "-K" to end of catalog number for item to be UL classified to ANSI/NSF Standard 61.



FEATURES

- All brass conforms to AWWA Standard C800 (ASTM B-62 and ASTM B-584, UNS NO C83600 - 85-5-5-5)
- Ends are integral or secured with adhesive to prevent unintentional disassembly.
- Hole for attaching handle is provided in tee-head.
- 300 PSI working pressure.
- Padlock Wing for locking valve in closed position.

Note: Recommended for inlet side shut-off.

Optional full 360° tee-head rotation. Add "R" to end of part number.

The Ford Meter Box Company considers the information in this submittal form to be correct at the time of publication. Item and option availability, including specifications, are subject to change without notice. Please verify that your product information is current.



The Ford Meter Box Company, Inc.

P.O. Box 443, Wabash, Indiana U.S.A. 46992-0443

Phone: 260-563-3171 / Fax: 800-826-3487

Overseas Fax: 260-563-0167

<http://www.fordmeterbox.com>

07/15/05

Submitted By: