

SUBMITTAL INFORMATION

Straight Ball Flange Meter Valves - (BFRW53-xxxW style)

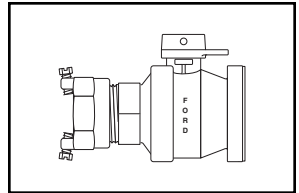

RECLAIMED WATER TEE-HEAD

PACK JOINT FOR IRON PIPE INLET BY METER FLANGE OUTLET

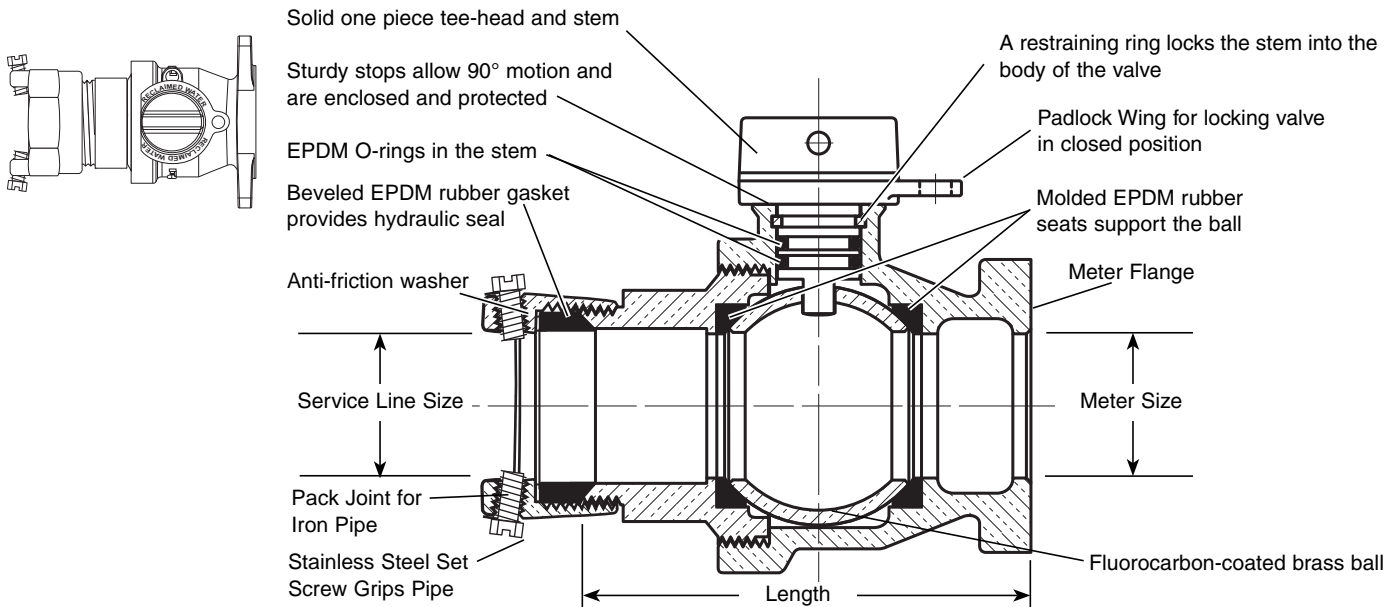

VALVE SIZE	SERVICE LINE SIZE	*METER SIZE	LENGTH	APPROX. WT. LBS	PART NUMBER	✓ SUBMITTED ITEM(S)
1-1/2"	1-1/2"	1-1/2"	6-5/8"	9.1	BFRW53-666W	
2"	2"	1-1/2" and 2"	7-3/16"	12.3	BFRW53-777W	

FEATURES

- All brass conforms to AWWA Standard C800 (ASTM B-62 and ASTM B-584, UNS NO C83600 - 85-5-5-5)
- Valve is non-directional and is watertight with flow in either direction.
- Ends are integral or secured with adhesive to prevent unintentional disassembly.
- Hole for attaching handle is provided in tee-head.
- 300 PSI working pressure.
- Padlock Wing for locking valve in closed position.
- Slotted holes are standard on 2" Flanged Meter Valves, allowing 1-1/2" Flange Meter connection.
- Includes a flat EPDM drop-in meter gasket.

Optional full 360° tee-head rotation. Add "R" to end of part number.

Optional Meter Support Brackets. Add "-MSB" to end of part number.

The Ford Meter Box Company considers the information in this submittal form to be correct at the time of publication. Item and option availability, including specifications, are subject to change without notice. Please verify that your product information is current.



The Ford Meter Box Company, Inc.

P.O. Box 443, Wabash, Indiana U.S.A. 46992-0443

Phone: 260-563-3171 / Fax: 800-826-3487

Overseas Fax: 260-563-0167

<http://www.fordmeterbox.com>

08/27/08

Submitted By: