

SUBMITTAL INFORMATION

Ball Valve Curb Stop - (BH64-233-G style)

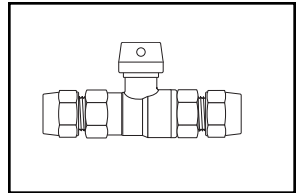

**5/8" VALVES WITH GRIP JOINT FOR POLYETHYLENE PIPE (PEP) INLET
BY GRIP JOINT FOR COPPER OR PLASTIC TUBING (CTS) OUTLET**

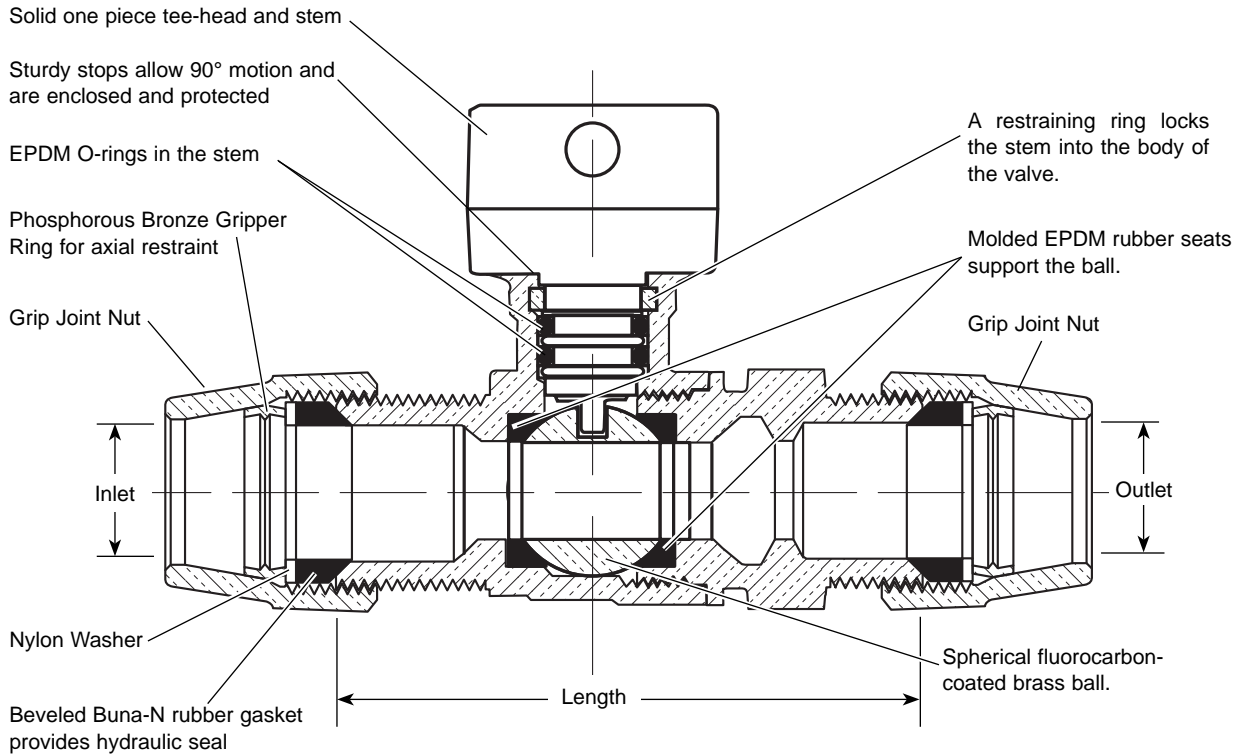

VALVE SIZE	INLET SIZE	OUTLET SIZE	LENGTH	APPROX. WT. LBS	PART NUMBER	✓ SUBMITTED ITEM(S)
5/8"	3/4"	3/4"	4-5/16"	2.2	▼ BH64-233-G	

▼ UL Classified to ANSI/NSF Standard 61.

Note: Ford recommends insert stiffeners when using plastic pipe or tubing



FEATURES

- All brass conforms to AWWA Standard C800 (ASTM B-62 and ASTM B584, UNS NO C83600 - 85-5-5-5)
- Valve is non-directional and is water tight with flow in either direction.
- Ends are integral or secured with adhesive to prevent unintentional disassembly.
- Hole for attaching curb box rod or handle is provided in the tee-head.
- 300 PSI working pressure.

Padlock Wing option is not available on BH-style curb stops.

Optional full 360° tee-head rotation. Add "R" to end of part number. Example: BH64-233R-G

The Ford Meter Box Company considers the information in this submittal form to be correct at the time of publication. Item and option availability, including specifications, are subject to change without notice. Please verify that your product information is current.



The Ford Meter Box Company, Inc.

P.O. Box 443, Wabash, Indiana U.S.A. 46992-0443

Phone: 260-563-3171 / Fax: 800-826-3487

Overseas Fax: 260-563-0167

<http://www.fordmeterbox.com>

11/05/03

Submitted By: