

# SUBMITTAL INFORMATION

## Steel Reducing Coupling - (FC6-xxxx-xxx-R style)

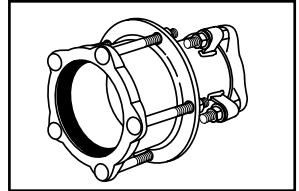

### 10" STYLE FC6 COUPLINGS FOR JOINING PIPES WITH DIFFERENT O.D.'S

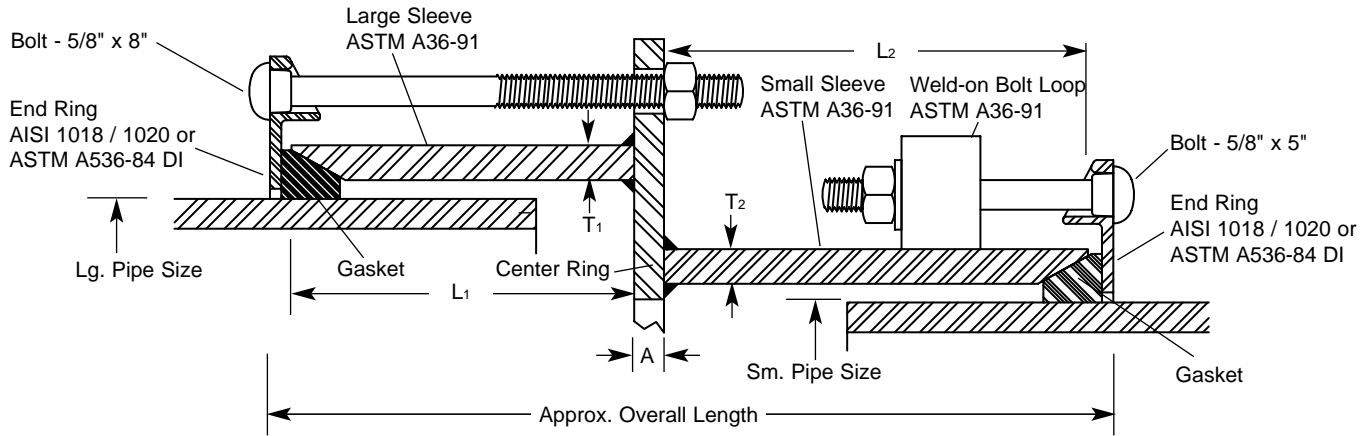

NOM PIPE SIZE	LARGE END					BY	NOM PIPE SIZE	SMALL END					DIM A	OVERALL LENGTH	APPROX. CATALOG NUMBER	✓ SUBMITTED ITEM(S)
	GASKET RANGE	LENGTH L <sub>1</sub>	BOLT QTY.	DIM T <sub>1</sub>				GASKET RANGE	LENGTH L <sub>2</sub>	BOLT QTY.	DIM T <sub>2</sub>					
10"	11.42-11.77	5"	6	1/4"			6"	6.00	7"	4	3/8"	3/8"	13-1/2"			
								6.63-6.90								
								6.90-7.20								
								7.21-7.56								
							8"	8.00	7"	5	3/8"	1/4"	13-1/2"			
								8.63-9.05								
								9.05-9.40								
								9.40-9.74								
10"	11.77-12.12	5"	6	1/4"			6"	6.00	7"	4	3/8"	3/8"	13-1/2"			
								6.63-6.90								
								6.90-7.20								
								7.21-7.56								
							8"	8.00	7"	5	3/8"	1/4"	13-1/2"			
								8.63-9.05								
								9.05-9.40								
								9.40-9.74								

**Note:** Flexible Couplings do not restrain axial forces on piping.

### FEATURES

- Sleeves: Carbon Steel per ASTM A36
- Center Ring: Carbon Steel per ASTM A36
- End Rings: Cold Rolled Carbon Steel per AISI 1020 or Ductile Iron per ASTM A536 (65-45-12)
- Bolts and Nuts: Low Alloy Steel per ASTM A536 or AWWA C111
- Gasket: SBR rubber per ASTM D2000 80M 4AA800
- Finish: Black Shop Coat

The Ford Meter Box Company considers the information in this submittal form to be correct at the time of publication. Item and option availability, including specifications, are subject to change without notice. Please verify that your product information is current.



**The Ford Meter Box Company, Inc.**

P.O. Box 443, Wabash, Indiana U.S.A. 46992-0443

Phone: 260-563-3171 / Fax: 800-826-3487

Overseas Fax: 260-563-0167

<http://www.fordmeterbox.com>

09/04/01

Submitted By: