

# SUBMITTAL INFORMATION

## Retrosetters - (*Retro-xBHH style*)

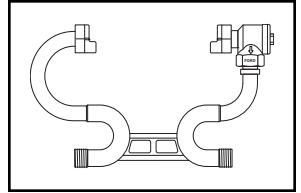

**NO VALVE INLET BY ANGLE CASCADING DUAL CHECK VALVE OUTLET**

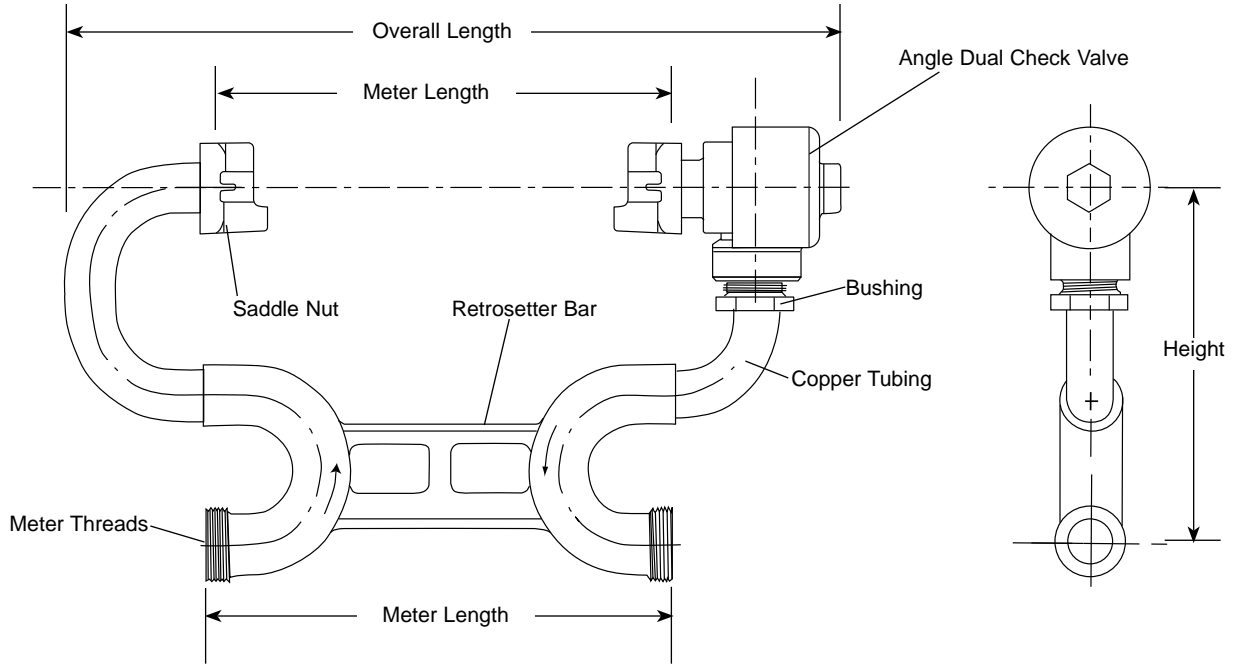

Meter Size	Meter Length	Overall Length	Approx. Height	Approx. Wt. Lbs.	Catalog Number	✓ Submitted Item(s)
5/8"	7-1/2"	13-5/8"	6"	4.1	RETRO-1BHH	
5/8"x3/4"	7-1/2"	13-5/8"	6"	4.4	RETRO-2BHH	
3/4"	9"	15-1/8"	6"	-	**RETRO-3BHH	
1"	10-1/2"	17-1/2"	8-3/8"	7.4	*RETRO-4B3HH	

\* This retrosetter is 1" throughout except the valve has 3/4" internal parts.

\*\* Manufactured with 13/16" O.D. tubing.

### FEATURES

- All brass conforms to AWWA Standard C800 (ASTM B-62 and/or ASTM B-584, UNS NO C83600 - 85-5-5-5)
- Style "B" Retrosetter positions the meter directly above the centerline of the service.
- Saddle Nuts hold the meter in place for tightening.
- All Ford Retrosetters are assembled with lead-free solder.
- Ford Retrosetters are furnished with four rubber gaskets, one for each meter nut and two for the bottom bar.
- Conforms to AWWA C700 for Meter Threads.
- Dual check valve is ASSE 1024 approved.

The Ford Meter Box Company considers the information in this submittal form to be correct at the time of publication. Item and option availability, including specifications, are subject to change without notice. Please verify that your product information is current.



#### The Ford Meter Box Company, Inc.

P.O. Box 443, Wabash, Indiana U.S.A. 46992-0443

Phone: 260-563-3171 / Fax: 800-826-3487

Overseas Fax: 260-563-0167

<http://www.fordmeterbox.com>

12/27/07

Submitted By: