

SUBMITTAL INFORMATION

Key Valve Branch Assembly - (UV13-xxW style)

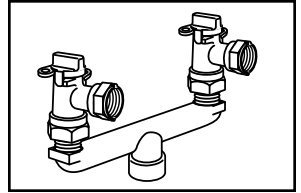

FEMALE IRON PIPE THREAD INLET BY TWO METER SWIVEL NUT OUTLETS

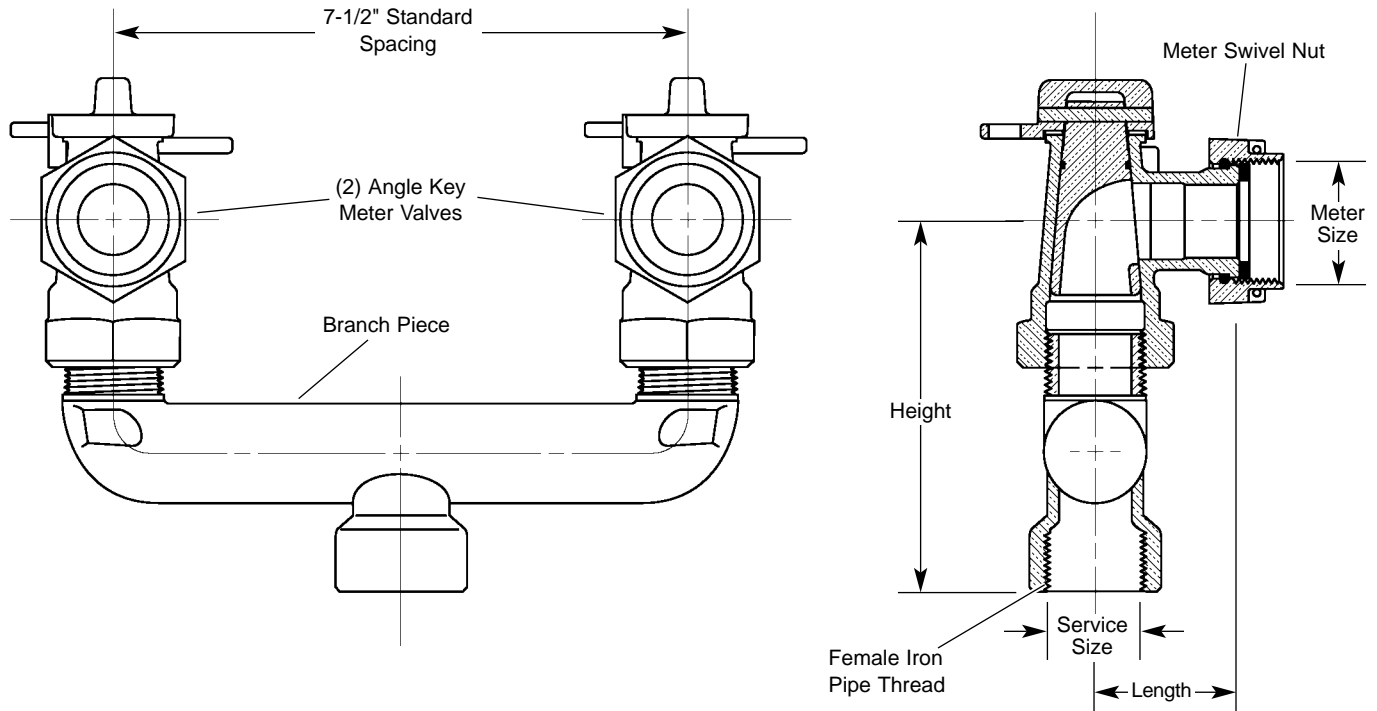

SERVICE SIZE	METER SIZE	LENGTH	HEIGHT	APPROX. WT. LBS.	Components		Assembly	✓ SUBMITTED ITEM(S)
					BRANCH PIECE	VALVES (2)	CATALOG NUMBER	
3/4"	5/8"	1-11/16"	4-5/16"	4.3	U18-33	KV13-331W	UV13-31W	
3/4"	5/8" x 3/4" or 3/4"	1-11/16"	4-5/16"	4.5	U18-33	KV13-332W	UV13-32W	
1"	5/8"	1-11/16"	4-5/16"	4.2	U18-43	KV13-331W	UV13-41W	
1"	5/8"	1-11/16"	4-5/16"	4.0	U18-43-65	KV13-331W	*UV13-41W-65	
1"	5/8" x 3/4" or 3/4"	1-11/16"	4-5/16"	4.4	U18-43	KV13-332W	UV13-42W	
1"	5/8" x 3/4" or 3/4"	1-11/16"	4-5/16"	4.3	U18-43-65	KV13-332W	*UV13-42W-65	

* Available with 6-1/2" spacing between centers of meter valves. Add "-65" to Catalog Number.

FEATURES

- All brass conforms to AWWA Standard C800 (ASTM B-62, UNS NO C83600 - 85-5-5-5)
- All Branch Valve Assemblies have Padlock Wings.
- Meter gaskets are furnished with all Branch Valve Assemblies.
- Meets 100 PSI pressure requirements of AWWA Standard C800.

The Ford Meter Box Company considers the information in this submittal form to be correct at the time of publication. Item and option availability, including specifications, are subject to change without notice. Please verify that your product information is current.



The Ford Meter Box Company, Inc.

P.O. Box 443, Wabash, Indiana U.S.A. 46992-0443

Phone: 260-563-3171 / Fax: 800-826-3487

Overseas Fax: 260-563-0167

<http://www.fordmeterbox.com>

09/04/01

Submitted By: