

# SUBMITTAL INFORMATION

## 70 Series Coppersetter - (VBHH72-xx-44-xx-G style)

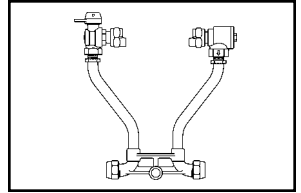

ANGLE BALL VALVE BY ANGLE DUAL CHECK VALVE (5/8" X 3/4" METER)

GRIP JOINT FOR COPPER OR PLASTIC TUBING (CTS) INLET AND OUTLET

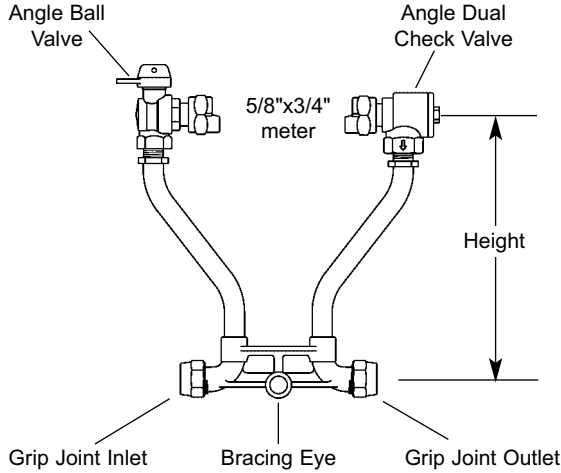

### Coppersetter Part Number

HEIGHT (INCHES)	APPROX. WT. LBS.	CATALOG NUMBER (INSERT SERVICE LINE CONN. SIZE)	√ SUBMITTED ITEM(S)
7	6.0	VBHH72-7W-44-xx-G	
9	6.2	VBHH72-9W-44-xx-G	
12	6.4	VBHH72-12W-44-xx-G	
15	6.6	VBHH72-15W-44-xx-G	
18	7.3	VBHH72-18W-44-xx-G	
21	7.5	VBHH72-21W-44-xx-G	
24	7.8	VBHH72-24W-44-xx-G	
27	8.0	VBHH72-27W-44-xx-G	
30	8.3	VBHH72-30W-44-xx-G	
33	8.6	VBHH72-33W-44-xx-G	
36	8.8	VBHH72-36W-44-xx-G	
39	9.1	VBHH72-39W-44-xx-G	
42	9.4	VBHH72-42W-44-xx-G	

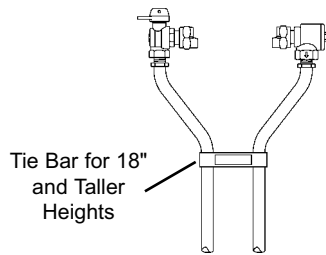

### Service Line Size

INLET	OUTLET	SERVICE LINE CONN. SIZE	√ SUBMITTED ITEM(S)
3/4" (CTS) G.J.	3/4" (CTS) G.J.	33	
1" (CTS) G.J.	3/4" (CTS) G.J.	43	
1" (CTS) G.J.	1" (CTS) G.J.	44	

**Note:** Ford recommends insert stiffeners when using plastic pipe or tubing

### FEATURES

- All brass conforms to AWWA Standard C800 (ASTM B-62, UNS NO C83600 - 85-5-5-5)
- Saddle Nuts hold the meter in place for tightening.
- Bracing Eye is standard on all 70 Series Coppersetters.
- Tie Bar is standard for 18" and taller Coppersetter heights (72 Series).
- 13/16" Copper Risers provide more flow capacity.
- All Ford Setters are assembled with lead-free solder.

The Ford Meter Box Company considers the information in this submittal form to be correct at the time of publication. Item and option availability, including specifications, are subject to change without notice. Please verify that your product information is current.



**The Ford Meter Box Company, Inc.**

P.O. Box 443, Wabash, Indiana U.S.A. 46992-0443

Phone: 260-563-3171 / Fax: 800-826-3487

Overseas Fax: 260-563-0167

<http://www.fordmeterbox.com>

10/11/00

Submitted By: