

SUBMITTAL INFORMATION

70 Series Coppersetter - (VBHH77-xxB11771525 style)

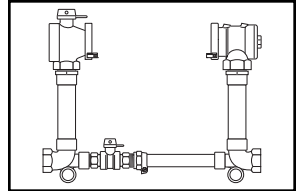

ANGLE BALL VALVE BY ANGLE DUAL CHECK VALVE (2" METER)

FEMALE IRON PIPE THREAD INLET AND OUTLET

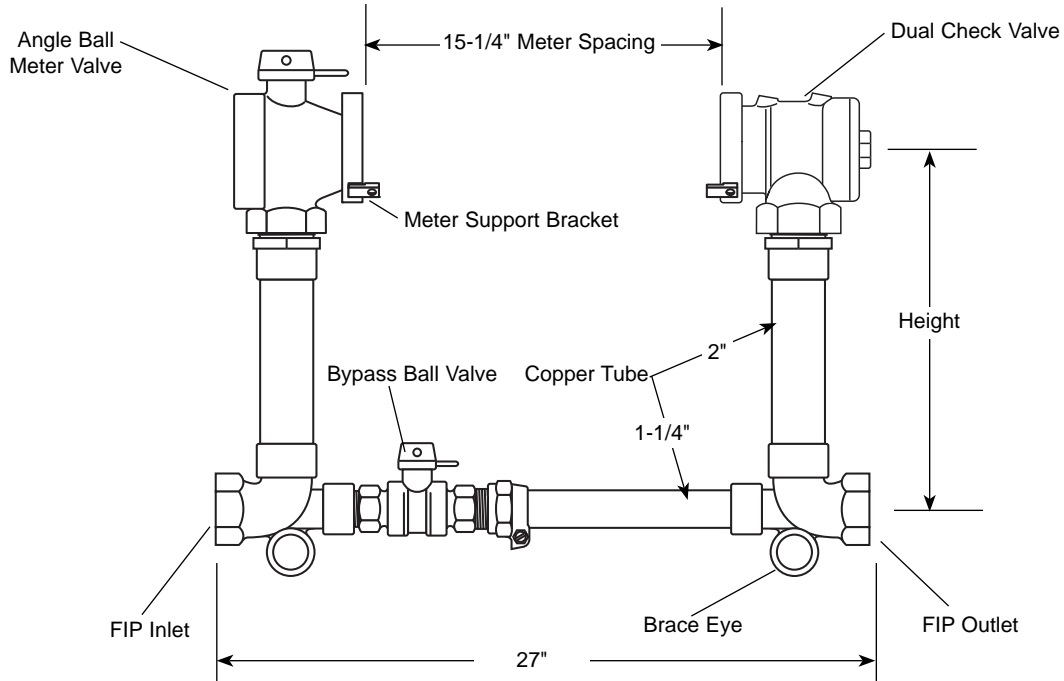

SERVICE LINE CONNECTION		HEIGHT	APPROX. WT. LBS.	CATALOG NUMBER	✓ SUBMITTED ITEM(S)
FIP INLET	FIP OUTLET				
2"	2"	12"	32	VBHH77-12B11771525	
		15"	33	VBHH77-15B11771525	
		18"	34	VBHH77-18B11771525	
		21"	34	VBHH77-21B11771525	
		24"	35	VBHH77-24B11771525	
		27"	35	VBHH77-27B11771525	
		36"	40	VBHH77-36B11771525	

FEATURES

- All brass conforms to AWWA Standard C800 (ASTM B-62 and ASTM B-584, UNS NO C83600 - 85-5-5-5)
- Constructed with Type K Copper and conforms to ASTM B-88, Copper Alloy #122.
- All Ford Meter Setters are assembled with lead-free solder.
- Bracing Eyes are standard.
- Meter Support Brackets are standard.
- Optional High Bypass - add "HB" following the height. Example: VBHH77-12HB11771525.
- Padlock Wing is standard on all Angle Meter Ball Valves and Key Valves.

The Ford Meter Box Company considers the information in this submittal form to be correct at the time of publication. Item and option availability, including specifications, are subject to change without notice. Please verify that your product information is current.



The Ford Meter Box Company, Inc.

P.O. Box 443, Wabash, Indiana U.S.A. 46992-0443

Phone: 260-563-3171 / Fax: 800-826-3487

Overseas Fax: 260-563-0167

<http://www.fordmeterbox.com>

11/21/07

Submitted By: