

SUBMITTAL INFORMATION

Inverted Key Curb Stop- Minneapolis Pattern - (Z22-xxxM style)

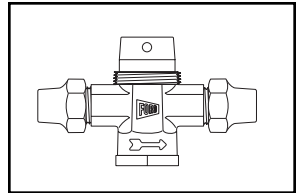

FLARE COPPER INLET AND OUTLET

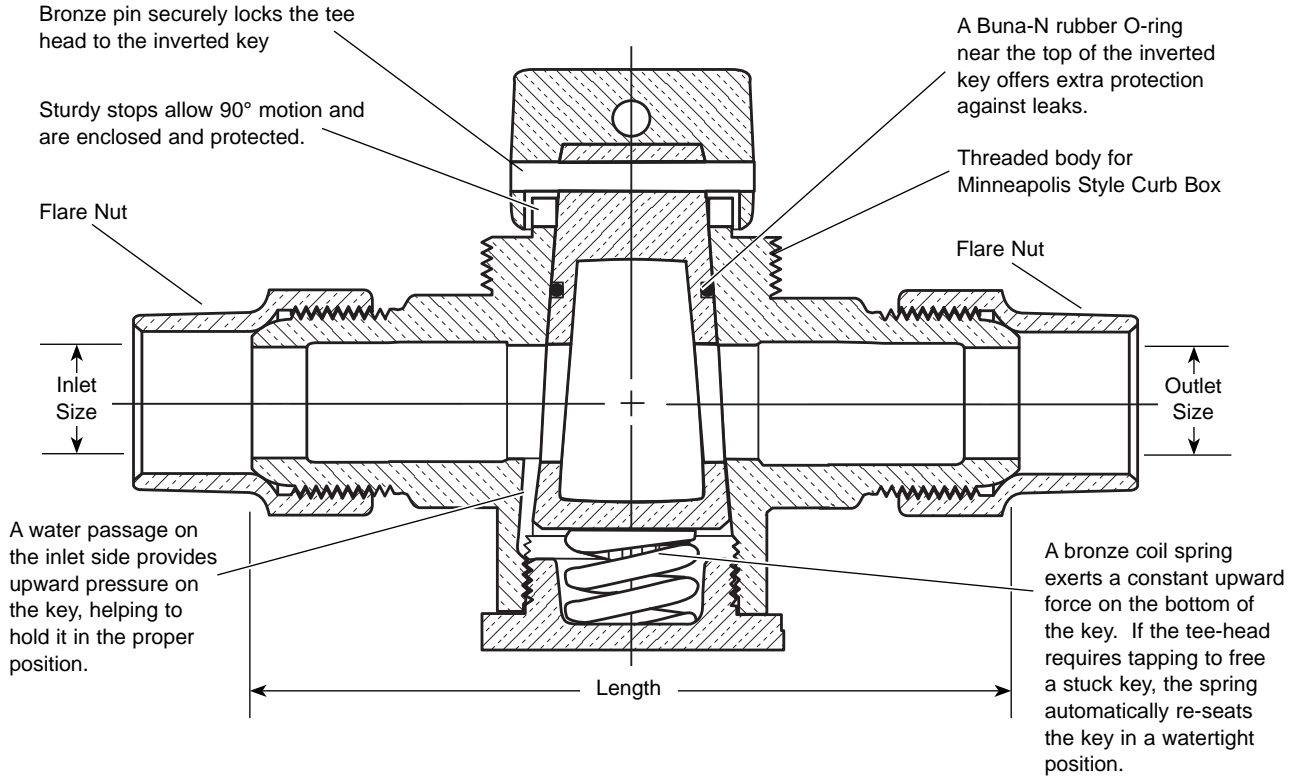

VALVE SIZE	INLET SIZE	OUTLET SIZE	LENGTH	APPROX. WT. LBS	PART NUMBER	✓ SUBMITTED ITEM(S)
3/4"	3/4"	3/4"	5-1/16"	2.9	▼ Z22-333M	
1"	1"	1"	6-1/16"	4.9	▼ Z22-444M	

▼ UL Classified to ANSI/NSF Standard 61.



FEATURES

- All brass conforms to AWWA Standard C800 (ASTM B-62 and ASTM B-584, UNS NO C83600 - 85-5-5-5)
- Hole for attaching curb box rod is provided in tee-head.
- 100 PSI working pressure.

Optional full 360° tee-head rotation. Add "R" to end of part number.

The Ford Meter Box Company considers the information in this submittal form to be correct at the time of publication. Item and option availability, including specifications, are subject to change without notice. Please verify that your product information is current.



The Ford Meter Box Company, Inc.

P.O. Box 443, Wabash, Indiana U.S.A. 46992-0443

Phone: 260-563-3171 / Fax: 800-826-3487

Overseas Fax: 260-563-0167

<http://www.fordmeterbox.com>

07/15/04

Submitted By: