

SUBMITTAL INFORMATION

Inverted Key Curb Stop - (Z41-xxx-G style)

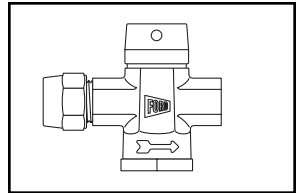

GRIP JOINT FOR COPPER OR PLASTIC TUBING (CTS) INLET BY FEMALE IRON PIPE THREAD OUTLET

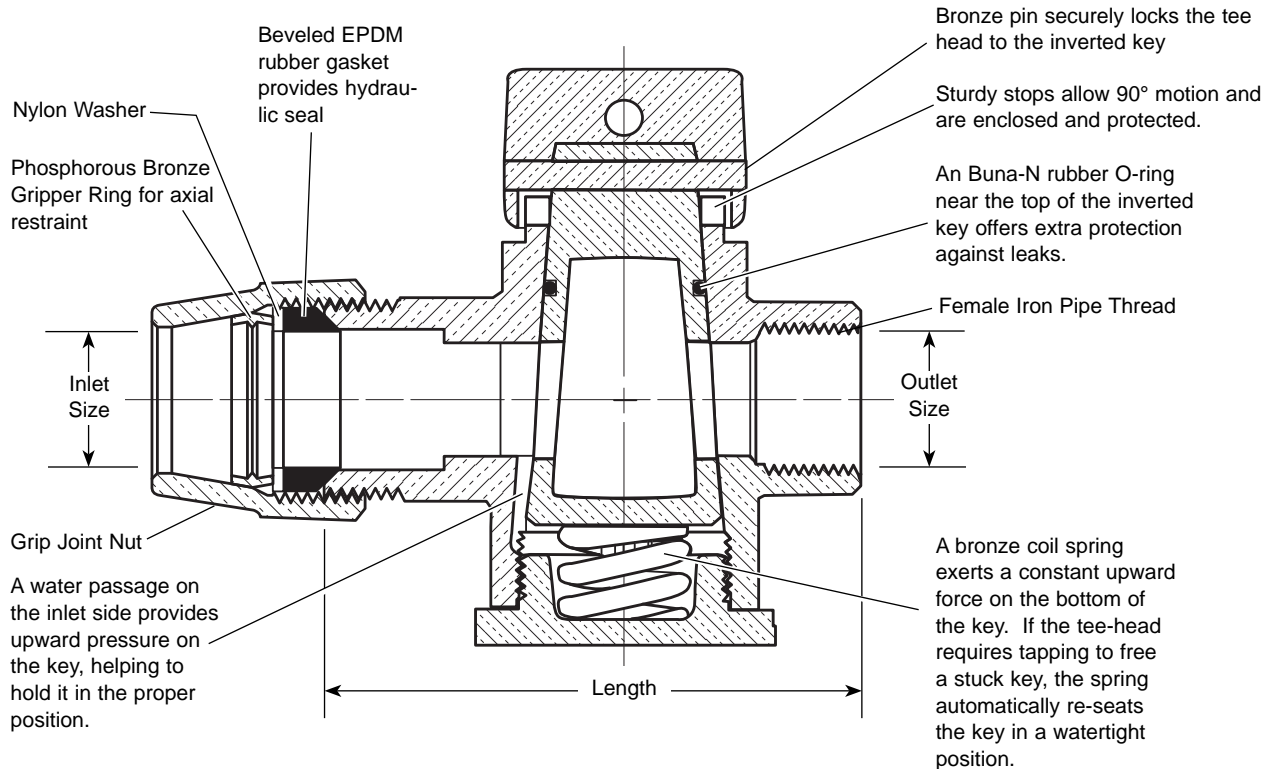

VALVE SIZE	INLET SIZE	OUTLET SIZE	LENGTH	APPROX. WT. LBS	PART NUMBER	SUBMITTED ITEM(S)
3/4"	3/4"	3/4"	3-13/16"	2.4	▼ Z41-333 -G	
1"	1"	1"	5-11/16"	4.1	▼ Z41-444 -G	

Note: Ford recommends using insert stiffeners with plastic pipe or tubing.

▼ UL Classified to ANSI/NSF Standard 61.



FEATURES

- All brass conforms to AWWA Standard C800 (ASTM B-62 and ASTM B-584, UNS NO C83600 - 85-5-5-5)
- Hole for attaching curb box rod is provided in tee-head.
- Meets 100 PSI pressure requirement of AWWA Standard C800.

Optional full 360° tee-head rotation. Insert "R" into part number.

The Ford Meter Box Company considers the information in this submittal form to be correct at the time of publication. Item and option availability, including specifications, are subject to change without notice. Please verify that your product information is current.



The Ford Meter Box Company, Inc.

P.O. Box 443, Wabash, Indiana U.S.A. 46992-0443

Phone: 260-563-3171 / Fax: 800-826-3487

Overseas Fax: 260-563-0167

<http://www.fordmeterbox.com>

10/18/05

Submitted By: