

4" - 8" / SERIES UFRCS1390

ASSEMBLY INSTRUCTIONS FOR RESTRAINED CASING SPACER / SUPPORT OF PIPE BELL JOINT

Refer to the Ford website (<http://www.fordmeterbox.com>) for additional and most recent installation instructions and product information.

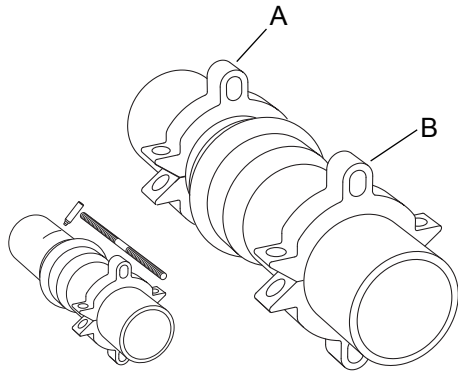

1. Remove standard clamping pad bolts from restraint ring and discard. Position a UFR1300 restraint ring onto pipe spigot and just behind bell end as shown. (use threaded rods as a guide to position restrainers) Make sure restraint ring ears A & B are properly aligned.

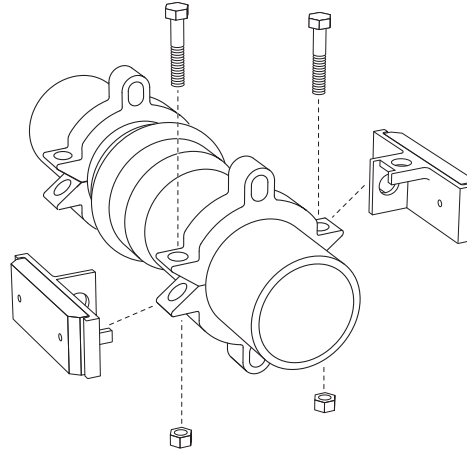

2. Place the runners on the clamping pads. Insert longer clamping pad bolts through restrainer and runner and tighten nuts evenly to recommended torques.

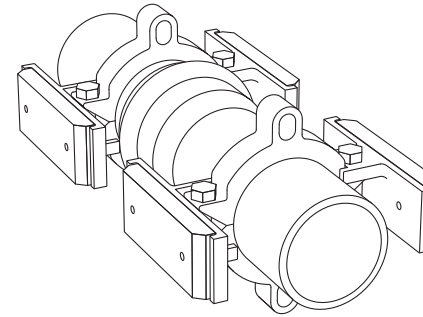

3. To assemble the second restraint ring with runners, repeat instructions #1 and #2. Assembled restraint rings with the runners should appear as shown above.

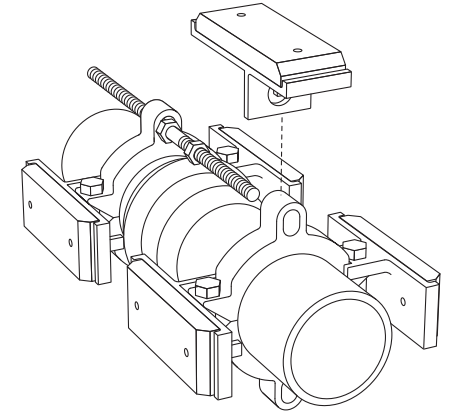

4. Install (2) nuts on the threaded rods. Thread a nut from each end of the threaded rod to the rod shank. Insert the threaded rod and runner as shown. (See insert below)

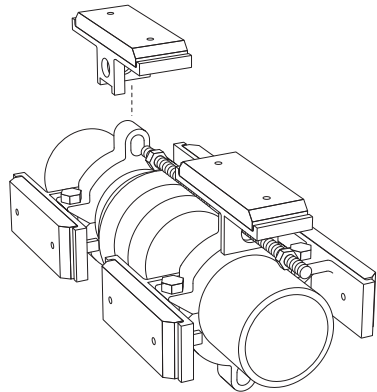

5. Install the next runner. The runners have cast guides designed to match with the restraint ring. Insert threaded rods and runner as shown.

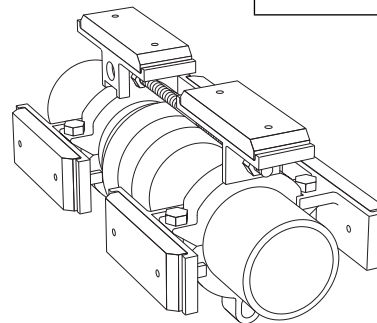

6. With the runners, threaded rods and nuts in place, tighten nuts behind restrainers. **Do not over-tighten nuts on the threaded rods.**

Minimum Recommended Clamping Pad Torque	
4" & 6"	100 ft-lb
8"	150 ft-lb

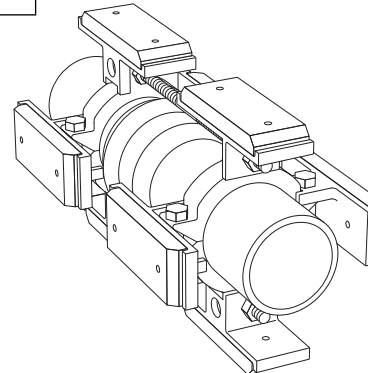

7. Install the second set of runners. Repeat steps #4, #5 and #6. Insert the runners, threaded rods and nuts as shown and tighten nuts behind restrainers. **Do not over-tighten nuts on the threaded rods.**

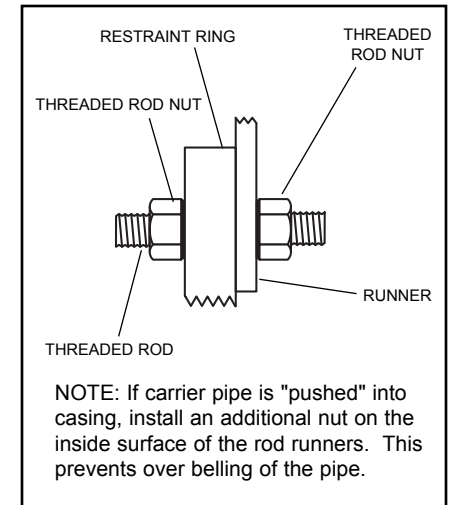

4" - 8" / SERIES UFRCS1390

ASSEMBLY INSTRUCTIONS FOR RESTRAINED CASING SPACER / SUPPORT OF PIPE BELL JOINT

Refer to the Ford website (<http://www.fordmeterbox.com>) for additional and most recent installation instructions and product information.

EXPLODED VIEW

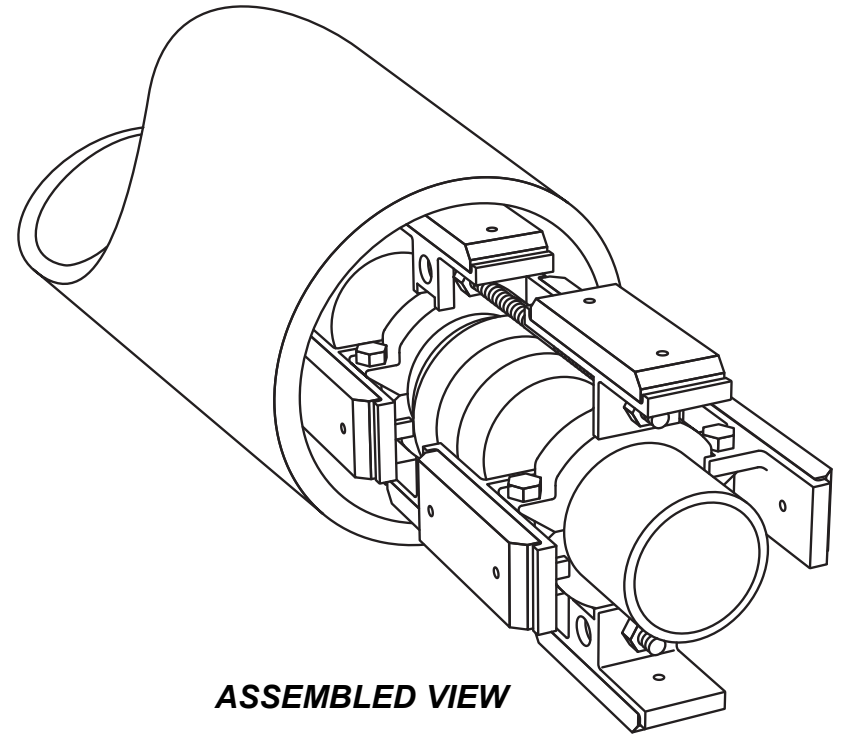
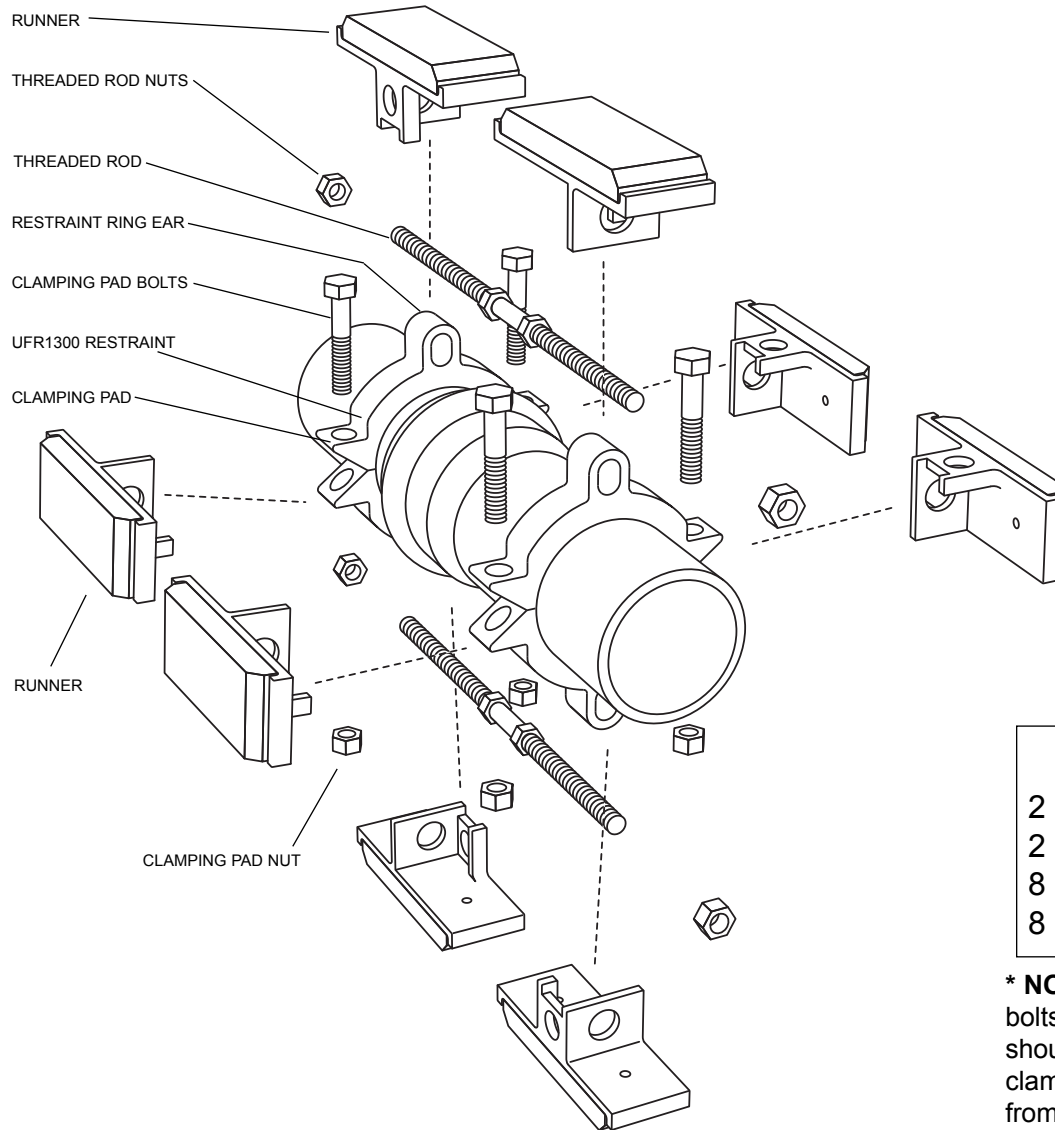

ASSEMBLED VIEW

PARTS LIST

- 2 - UFR1300 RESTRAINTS
- 2 - THREADED RODS
- 8 - NUTS FOR THREADED RODS
- 8 - RUNNERS

* **NOTE:** Restraint rings are shipped with standard bolts attaching the two halves together. These should be removed and replaced with longer clamping bolts provided in the kit. Re-use the nuts from the standard bolts that were removed.

