

Specifications - Uni-Flange® Series 1360

Series 1360 Uni-Flange® Restraint Device for PVC Pressure Fittings

More and more municipalities and consulting engineers are specifying PVC pipe joined with PVC Pressure Fittings.

Uni-Flange® now offers the fastest, most economical, and reliable method of restraining PVC Pressure Fittings... The Series 1360. Complete fitting restraint in a matter of minutes... using only a wrench.

The Uni-Flange® Series 1360 consists of two split rings... A Series 1300 installed on the PVC pipe, connected to a specially designed back-up ring that seats securely behind the fitting bell. The back-up ring is beveled on the leading edge and the two halves are designed to interlock... no clamping bolts are required.

The Uni-Flange® Series 1360 offers guaranteed joint restraint every time... eliminating the need for expensive and time consuming concrete thrust blocks. No waiting for trucks. No building forms. Trenches can be backfilled immediately. The 1360 keeps the job moving.

Split Ring Restraint - Uni-Flange®

Series 1300 is made from Ductile Iron per ASTM A536, Grade 65-45-12, or ASTM A36 Structural Steel.

Color Code:

Black for PVC with ductile iron pipe O.D.

Gray for PVC with steel pipe O.D.

Contact factory for coating options.

Side Clamping Bolts and Nuts

Connecting Rods - High strength, low alloy steel per ANSI / AWWA C111/A21.11.
Optional: Type 304 Stainless Steel

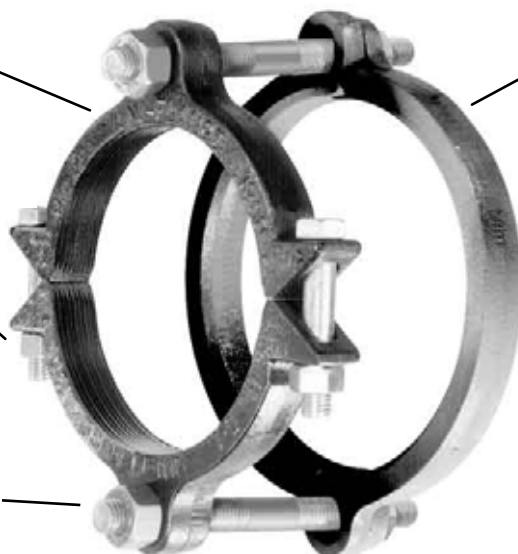

Split Back-Up Ring - Ductile Iron per ASTM A536, Grade 65-45-12 or Steel per ASTM A36.



Series 1360 Installed

Applications / Pressure Rating

The Uni-Flange® Series 1360 carries a water working pressure rating of 150 PSI in 2" through 8" nominal sizes. Larger sizes carry the same pressure rating as the fittings on which they are installed. (Contact fitting manufacturer for rating.) The bell run O.D. is required for sizes 14" and larger. All sizes incorporate a minimum 2:1 safety factor at the full rated pressure.

Suggested Specification - Series 1360

Restraint Devices for PVC Pipe and PVC Pressure Fittings shall consist of a split restraint ring installed on the spigot, connected to a split back-up ring that seats behind the gasket race of the fitting. The split restraint ring shall incorporate a series of serrations on the inside diameter to provide positive restraint, exact fit and 360° contact and support of the pipe wall. The two halves of the split back-up ring shall form a beveled leading edge to assure exact fit behind the fitting gasket race. Restraint Devices shall be of ductile iron, ASTM A536, Grade 65-45-12, or ASTM A36 structural steel and connecting rods shall be of high strength, low alloy material in accordance with ANSI / AWWA C111 / A21.11. Restraint Devices shall be Uni-Flange® 1360 or approved equal.

Uni-Flange® Series 1360 Pipe Restraint

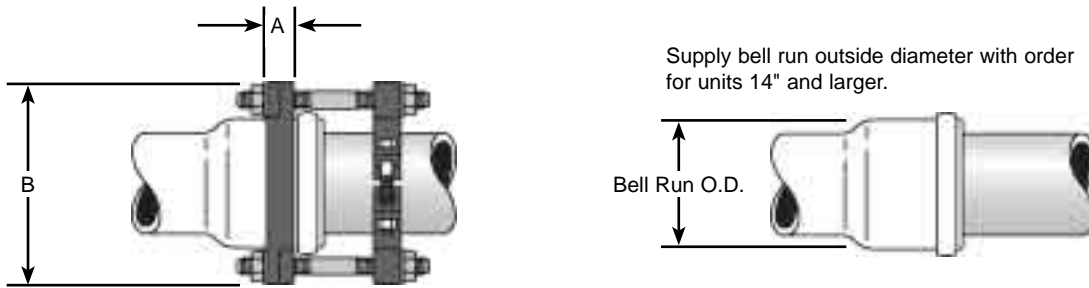

Supply bell run outside diameter with order for units 14" and larger.

Restraint Device For AWWA C-907 PVC Pressure Fittings

| NOM. PIPE SIZE | PIPE O.D. (INCHES) | A | B APPROX. | CATALOG NUMBER FOR FITTINGS | CONNECTING RODS NUMBER AND SIZE | SIDE BOLT QUANTITY AND SIZE | | APPROX. WT. LBS. |
|----------------|--------------------|--------|-----------|-----------------------------|---------------------------------|-----------------------------|-------------------|------------------|
| | | | | | | RESTRAINT | BACK-UP RING | |
| 4" | 4.80 | 1-1/8" | 9-1/8" | UFR1360-C-4-(I or U) | (2) 3/4"x12" | (2) 5/8"x3-1/2" | - | 13.5 |
| 6" | 6.90 | 1-1/8" | 11-7/8" | UFR1360-C-6-(I or U) | (2) 3/4"x12" | (2) 5/8"x3-1/2" | - | 18.0 |
| 8" | 9.05 | 1-1/8" | 14-9/16" | UFR1360-C-8-(I or U) | (2) 3/4"x12" | (2) 3/4"x4" | - | 29.0 |
| 10" | 11.10 | 4" | 19-11/16" | UFR1360-C-10-(I or U) | (4) 3/4"x17" | (2) 7/8"x5" | (2) 7/8" x 3-1/2" | 54.5 |
| 12" | 13.20 | 4" | 21-15/16" | UFR1360-C-12-(I or U) | (4) 3/4"x24" | (2) 7/8"x5" | (2) 7/8" x 3-1/2" | 81.0 |
| 14" | 15.30 | 4" | 24-1/4" | *UFR1360-C-14-(I or U) | (6) 3/4"x24" | (4) 7/8"x7" | (4) 7/8"x7" | 127.0 |
| 16" | 17.40 | 4" | 26-9/16" | *UFR1360-C-16-(I or U) | (6) 3/4"x30" | (4) 7/8"x7" | (4) 7/8"x7" | 140.0 |
| 18" | 19.50 | 4" | 28-7/8" | *UFR1360-C-18-(I or U) | (8) 3/4"x30" | (4) 1"x7" | (4) 7/8"x7" | 181.0 |
| 20" | 21.60 | 5" | 31-1/8" | *UFR1360-C-20-(I or U) | (8) 3/4"x30" | (4) 1-1/8"x9" | (4) 1" x 9" | 227.0 |
| 24" | 25.80 | 5" | 35-7/8" | *UFR1360-C-24-(I or U) | (12) 3/4"x36" | (4) 1-1/8"x9" | (4) 1" x 9" | 328.0 |
| 30" | 32.00 | 7" | 44-1/16" | *UFR1360-C-30-(I or U) | (12) 1"x40" | (8) 1-1/8"x9" | (6) 1-1/8" x 9" | 551.0 |
| 36" | 38.30 | 7" | 51-15/16" | *UFR1360-C-36-(I or U) | (12) 1"x40" | (8) 1-1/8"x9" | (6) 1-1/8" x 9" | 583.0 |

* The bell run outside diameter must be provided. Contact factory for details.

I = Import Casting **U** = Domestic Casting

Restraint Device For IPS Class 200 PVC Fittings

| NOM. PIPE SIZE | PIPE O.D. (INCHES) | A | B | CATALOG NUMBER | CONNECTING RODS QUANTITY AND SIZE | SIDE BOLTS QUANTITY AND SIZE | APPROX. WT. LBS. |
|----------------|--------------------|--------|----------|----------------|-----------------------------------|------------------------------|------------------|
| 2" | 2.38 | 1-1/8" | 6-3/8" | UFR1360-S-2-I | (2) 5/8"x11" | (2) 5/8"x3-1/2" | 9.5 |
| 2-1/2" | 2.88 | 1-1/8" | 6-7/8" | UFR1360-S-25-I | (2) 5/8"x11" | (2) 5/8"x3-1/2" | 10.0 |
| 3" | 3.50 | 1-1/8" | 7-5/8" | UFR1360-S-3-I | (2) 5/8"x11" | (2) 5/8"x3-1/2" | 10.5 |
| 4" | 4.50 | 1-1/8" | 9-1/8" | UFR1360-S-4-I | (2) 3/4"x12" | (2) 5/8"x3-1/2" | 14.0 |
| 6" | 6.63 | 1-1/8" | 11-9/16" | UFR1360-S-6-I | (2) 3/4"x12" | (2) 5/8"x3-1/2" | 17.5 |
| 8" | 8.63 | 1-1/8" | 13-3/8" | UFR1360-S-8-I | (2) 3/4"x12" | (2) 3/4"x4" | 26.0 |

Contact factory for information on sizes larger than 8".

I = Import Casting

Installation Instructions

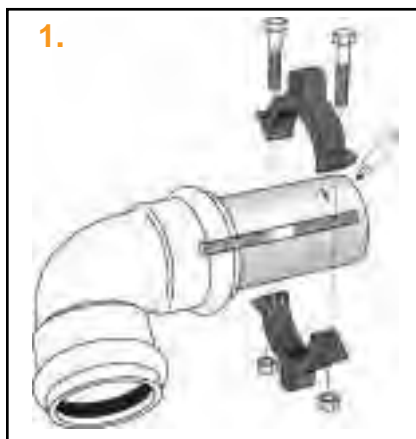

1. Install pipe into fitting. Install Series 1300 split clamping ring on the spigot end of the pipe. (Use connecting rod as a guide to position serrated restrainer.) Tighten clamping bolts evenly to the recommended torque.



2. Install split back-up ring behind gasket race of fitting. Make sure the bevel faces the gasket race. The two halves interlock at the bolt holes.

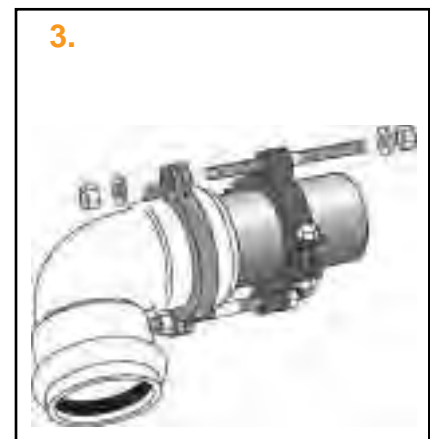

3. Insert rods through Series 1300 and back-up ring. Place washers against restrainer and back-up ring ears. Snug retaining nuts against washers. Do not overtighten retaining nuts. (Hand tight - then one full turn.)