

Uni-Flange® Series 1400

Wedge Action MJ Retainer Gland Joint Restraint for Ductile Iron Pipe

WORKING PRESSURE - 3" THROUGH 16" 350 PSI
 - 18" THROUGH 36" 250 PSI

Actuating Screw -

Ductile iron wedge actuating screw, with the Auto-Tork break-away head design, ensures proper torque during installation.

Gland -

Gland body is of High Strength Ductile Iron per ASTM A536, Grade 65-45-12. Compatible with all mechanical joints conforming to ANSI / AWWA C111 / A21.11.

Color Code:

All components black epoxy coated applied by the ecoat process.



3" THROUGH 36" SIZES - 100% DUCTILE IRON CONSTRUCTION

Wedges are ductile iron and heat treated to a hardness of 370 BHN minimum.

The Uni-Flange® Series 1400 offers a minimum 2:1 safety factor at the full rated pressure of the device, in all sizes, when tested in dead-end situations.

Note: UFR1400s are not to be used on plain end fittings.

Uni-Flange® Series 1400 Installation Instructions



1. Clean the socket and plain end. Lubricate gasket and plain end with approved pipe lubricant meeting AWWA C111. Place the gland on the plain end with the lip extension toward the plain end, followed by the gasket with the tapered edge of the gasket toward the plain end.

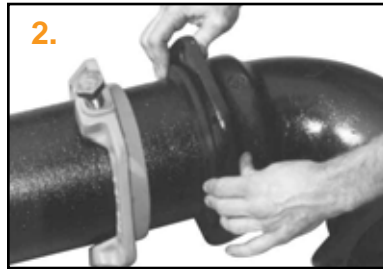

2. Insert the pipe into the socket and press the gasket firmly and evenly into the gasket recess. Keep the joint straight during assembly.



3. Push the gland toward the socket and center it around the pipe with the gland lip against the gasket. Hand tighten the Auto-Tork actuating screws to center the gland around the pipe. Insert T-bolts and hand tighten nuts. With the gland positioned and centered around the pipe, loosen the Auto-Tork actuating screws and continue to tighten the T-bolts. Set deflection after joint assembly but before tightening bolts (max. deflection is 5°).

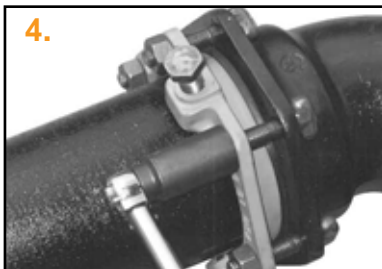

4. Tighten the T-bolts to the same torque recommended in AWWA C111 (**45-60 ft-lb on 3", 75-90 ft-lb on 4" - 24" sizes, 100-120 ft-lb on 30" - 36" sizes**). Tighten in an alternating manner (12 o'clock, 6 o'clock, 9 o'clock, 3 o'clock), maintaining the same gap between the gland and the face of the MJ socket. Repeat the process until all bolts are within the approximate torque range. Use of a torque wrench is recommended.



5. After correct assembly of the mechanical joint, bring all wedges in contact with the pipe surface by turning the Auto-Tork actuating screws in a clockwise direction until contact is made and screw is "hand tight."



6. Tighten each Auto-Tork actuating screw by turning approximately 180 degrees (1/2 turn), alternating among screws until the break away heads twist off.

Note: The Series 1400 can be re-used or re-installed after the Auto-Tork screw heads have been twisted off. In this case, tighten the hex head of the wedge activating screw to 75 - 110 ft-lb.

Uni-Flange® Series 1400

Information - Wedge Action MJ Retainer Gland for Ductile Iron Pipe

HISTORY

The Series 1400 was originally designed to provide joint restraint for ductile iron pipelines installed in areas subject to earthquakes. Its unique “controlled expansion and flexibility” feature has allowed it to withstand several major earthquakes; one as large as magnitude 7.7 in 1983 and another of magnitude 7.8 in 1993. Uni-Flange® has licensed this technology and has adapted the design to AWWA standards and dimensions.

HOW IT WORKS

The Series 1400 is a mechanical joint restraining gland, incorporating individually actuated wedges located around the circumference of the pipe. When the specially designed wedge actuating screws are tightened, the teeth on the bottom of each wedge lock onto the pipe surface. Under normal operating conditions, this is all the restraint that is required. If external forces cause the pipe to move, the wedge teeth remain locked on the pipe and the wedge moves against the actuating screw, enclosed in its ductile iron pocket. This feature allows the joint to prevent separation yet remain resilient and flexible after assembly. In high pressure applications, or when surge pressures occur, the 1400 uses the line pressure to increase its restraining grip on the pipe. If the pressure decreases, the wedge returns to its original position and controlled expansion and flexibility are available again.



ADVANTAGES OF THE SERIES 1400

- **Eliminates** the need of costly and time consuming **concrete thrust blocks**.
- **“Auto-Tork” wedge actuating screws assure proper installation.** Auto-Tork screws are designed with a break away head that twists off at the recommended torque, leaving a hex head in case future maintenance or removal is required. This gives a visual indicator and ensures correct installation every time.
- **Wedges are contoured to fit the pipe.** This provides greater surface area contact, increasing the restraint capability and distributing the restraining force. The Series 1400 can be used on any thickness or class of ductile iron pipe.
- **High Pressure Capabilities.** The Series 1400 is rated at 350 psi in 3" - 16" nominal sizes, 250 psi in 18" - 36". Minimum 2:1 safety factor in all sizes.
- **Proven Technology.** The Series 1400 design has decades of successful field service.
- **The Series 1400 Offers 5° deflection** on sizes 3"-12", **3° deflection** on sizes 14"-24" and **1° deflection** on 30" and 36" sizes. This advantage is provided even after installation and pressurization.
- **No special tools necessary.** Designed for use with standard mechanical joint bells conforming to AWWA C111. The same wrench used to tighten the T-bolt nuts can be used on the wedge actuating screws.
- **Wedges are mechanically retained in pockets.** The Series 1400 wedges cannot fall out! All necessary parts show up at the job site and no parts are lost in the trench if the gland is removed from the pipe for system maintenance or relocation.
- **Used with ordinary ductile iron pipe and mechanical joint sockets.** There is no need to order, pay for, and wait for special factory fabricated parts. Totally field adaptable; no beveling, special segments, or welded rings required.
- **4" - 12" UL listed and FM approved.** Contact factory for details.



Listed



Uni-Flange® Series 1400

Information - Wedge Action MJ Retainer Gland Joint Restraint for Ductile Iron Pipe

- ① Auto-Tork break-away head, 1-1/4" across the flat (same as 3/4" heavy hex nut).
- ② 5/8" hex-head, operating screw.
- ③ Rubber spacer (positions wedge during assembly).
- ④ Wedge

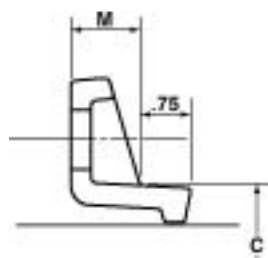
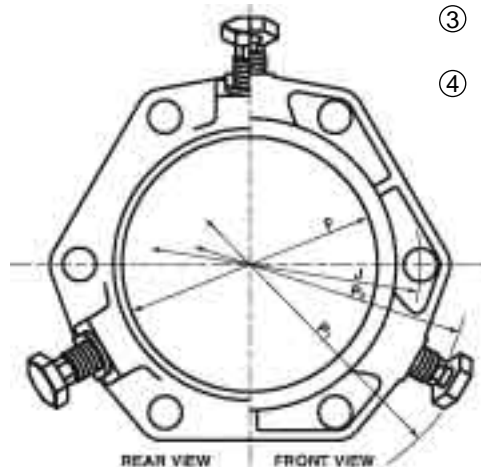

GLAND BODY DETAIL

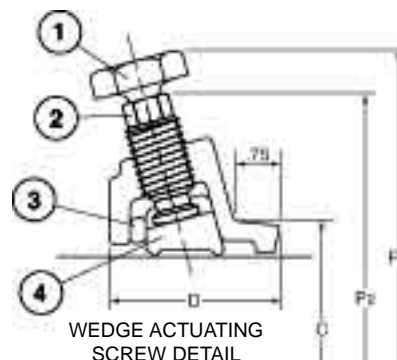

WEDGE ACTUATING SCREW DETAIL

Series 1400 Retainer Gland for Ductile Iron Pipe

NOM. PIPE SIZE	PIPE O.D. (INCHES)	CATALOG NUMBER	PRESSURE RATING (PSI)	No. OF WEDGES	APPROX. WEIGHT (LBS.)	P1*	P2**	C	D	F	M	J	No. OF BOLT HOLES
3"	3.96	UFR1400-D-3-(I or U)	350	2	6.0	11.04	9.06	4.84	2.65	4.06	0.68	6.19	4
4"	4.80	UFR1400-D-4-(I or U)	350	2	7.5	11.9	10.0	5.92	2.65	4.90	0.88	7.50	4
6"	6.90	UFR1400-D-6-(I or U)	350	3	11.0	14.0	12.1	8.02	2.65	7.00	0.88	9.50	6
8"	9.05	UFR1400-D-8-(I or U)	350	4	14.5	16.2	14.3	10.17	2.65	9.15	1.10	11.75	6
10"	11.10	UFR1400-D-10-(I or U)	350	6	22.0	18.2	16.3	12.22	2.75	11.20	1.10	14.00	8
12"	13.20	UFR1400-D-12-(I or U)	350	8	28.0	20.3	18.4	14.32	2.75	13.30	1.10	16.25	8
14"	15.30	UFR1400-D-14-(I or U)	350	10	42.0	22.9	20.9	16.40	3.00	15.44	1.50	18.75	10
16"	17.40	UFR1400-D-16-(I or U)	350	12	50.0	25.0	23.0	18.50	3.00	17.54	1.56	21.00	12
18"	19.50	UFR1400-D-18-(I or U)	250	12	67.0	28.1	25.8	20.60	3.05	19.64	1.65	23.25	12
20"	21.60	UFR1400-D-20-(I or U)	250	14	75.0	30.2	27.9	22.70	3.10	21.75	1.70	25.50	14
24"	25.80	UFR1400-D-24-(I or U)	250	16	85.0	34.4	32.1	26.90	3.20	25.94	1.85	30.00	16
30"	32.00	*** UFR1400-D-30-(I or U)	250	20	221.0	40.6	38.6	33.29	3.55	32.17	2.25	36.88	20
36"	38.30	*** UFR1400-D-36-(I or U)	250	24	256.0	46.9	44.9	39.59	3.76	38.47	2.25	43.75	24

I = Import Casting U = Domestic Casting

All dimensions in inches unless otherwise stated.

* Maximum O.D. of gland on pipe before break-away heads have been removed (as received).

** Maximum O.D. of gland on pipe after wedges have been activated and break-away heads have been removed.

*** 30" and 36" sizes include a Uni-Seal gasket.

Note: 4" - 12" oversized 1400 Retainer Glands are available for Class C and D gray cast iron (Color Coded Gray). To order these oversized units, add "-XL" to the end of the catalog number. Example: UFR1400-D-6-XL.

Note: Not to be used on plain end fittings.

Uni-Flange® Series 1400

Wedge Action MJ Retainer Gland Joint Restraint for Ductile Iron Pipe

SERIES 1400 WEDGE ACTION RETAINER GLAND PACKAGED WITH ACCESSORIES



PACKAGE CONTAINS

- 1 - Series 1400 Wedge Action retainer gland.
- 1 - Set of high strength, low alloy T-bolts & nuts (AWWA C111).
- 1 - Mechanical joint gasket (AWWA C111) 3" - 24" sizes, Uni-Seal Gasket 30" - 36" sizes.

3" through 12" sizes are shrink wrapped in a weather resistant carton. 14" through 36" sizes are bulk packaged.

Series 1400-DA Wedge Action Retainer Gland for Ductile Iron Pipe

NOM. PIPE SIZE	PIPE O.D. (INCHES)	CATALOG NUMBER	NO. OF WEDGES	PRESSURE RATING (PSI)	APPROX. WEIGHT (LBS.)
3"	3.96	UFR1400-DA-3-(I or U)	2	350	8.0
4"	4.80	UFR1400-DA-4-(I or U)	2	350	10.5
6"	6.90	UFR1400-DA-6-(I or U)	3	350	15.5
8"	9.05	UFR1400-DA-8-(I or U)	4	350	19.8
10"	11.10	UFR1400-DA-10-(I or U)	6	350	29.5
12"	13.20	UFR1400-DA-12-(I or U)	8	350	35.0
14"	15.30	UFR1400-DA-14-(I or U)	10	350	52.0
16"	17.40	UFR1400-DA-16-(I or U)	12	350	62.0
18"	19.50	UFR1400-DA-18-(I or U)	12	250	79.0
20"	21.60	UFR1400-DA-20-(I or U)	14	250	88.0
24"	25.80	UFR1400-DA-24-(I or U)	16	250	101.0
30"	32.00	UFR1400-DA-30-(I or U)	20	250	262.0
36"	38.30	UFR1400-DA-36-(I or U)	24	250	306.0

30" and 36" sizes include a Uni-Seal Gasket.

I = Import Casting U = Domestic Casting

Note: Not to be used on plain end fittings.

Sample Specification – Series 1400

Restraint for standardized mechanical joints shall be incorporated in the design of the follower gland and shall impart multiple points of wedge action against the pipe, increasing its resistance as the pressure increases. The assembled joint shall maintain its flexibility after burial and shall maintain its integrity by a controlled and limited expansion of each joint during the wedging action. Restraining glands shall be manufactured of high strength ductile iron conforming to the requirements of ASTM A536, Grade 65-45-12. Wedges shall be contoured to properly fit on the pipe, and shall be manufactured of ductile iron, heat treated to a minimum hardness of 370 BHN. Dimensions of the glands shall be such that they can be used with the standardized mechanical joint bell and tee head bolts conforming to the requirements of ANSI/AWWA C111/A21.11 and ANSI/AWWA C153/A21.53 of latest revision. Twist-off heads shall be incorporated in the design of the wedge actuating screws to ensure proper torque. The mechanical joint restraining device shall have a water working pressure rating of 250 psi minimum with a safety factor of at least 2:1 against separation when tested in a dead-end situation, and shall be Uni-Flange® Series 1400 or approved equal.