

Uni-Flange® Series 1450 Wedge Action Restrainer

for Push-On Joints of Ductile Iron Pipe (New Installations Only)

The 1450 consists of a Series 1400 wedge action retainer gland installed on the pipe spigot, connected with high strength, low alloy rods to a ductile iron backup ring that seats behind the pipe bell. It offers the following advantages:

- Fast, economical restraint of push-on pipe bells. There is no need for special (and expensive) “factory restrained joint” pipe.
- High pressure capabilities. Rated at 350 psi in 3" through 16" sizes, 250 psi in 18" through 36" sizes. Minimum 2:1 safety factor at full rated pressure.
- Recommended for any thickness class or pressure class of ductile iron pipe. The contoured wedges of the 1400 component fit the pipe properly. They spread the restraining force around the circumference of the pipe and maximize performance. There is no point loading of the pipe.

Installation Instructions

1. Install the ductile iron backup ring behind the bell, with the lip extension of the gland facing the bell.
2. Place the Series 1400 wedge action retainer gland on the spigot with the lip extension toward the bell.
3. Assemble the push-on joint of pipe per the pipe manufacturer's instructions.
4. Using a rod as a measuring tool, position the 1400 on the pipe spigot so that several threads of the connecting rod will extend through the bolt holes of the 1400 when it is connected to the backup ring.
5. Align the gland and 1400 and install the rods and nuts in each of the bolt holes.
6. Activate the 1400 restraint by tightening the “Auto-Tork” wedge actuating screws in a clockwise manner until they are all in contact with the pipe surface. Continue tightening in an alternating manner until all of the “Auto-Tork” heads twist off.
7. Tighten the nuts on the connecting rods until the mechanical joint gland is seated firmly against the back of the pipe bell.

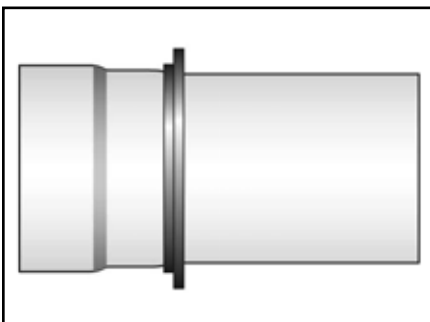

Install the ductile iron backup ring behind the bell, with the lip extension of the gland facing the bell.

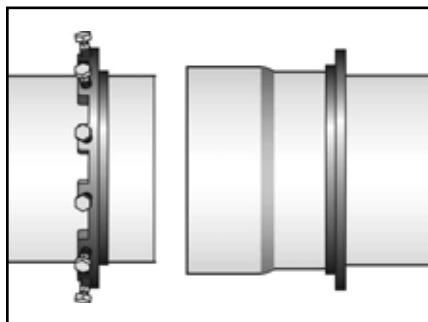

Place the Series 1400 wedge action retainer gland on the spigot with the lip extension toward the bell. Assemble the push-on joint per the pipe manufacturer's instructions.

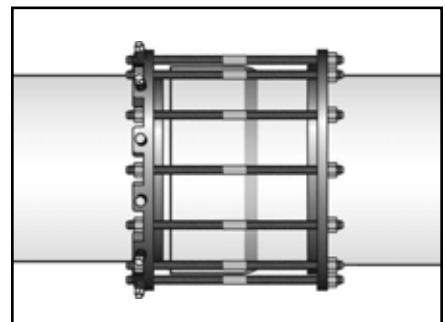

Align the gland and 1400 and install the rods and nuts in each of the bolt holes. Tighten the “Auto-Tork” wedge actuating screws in an alternating manner until the heads twist off. Tighten the connecting rod nuts until the backup ring seats against the bell.

Uni-Flange® Series 1450 Wedge Action Restrainer

for Push-On Joints of Ductile Iron Pipe (New Installations Only)

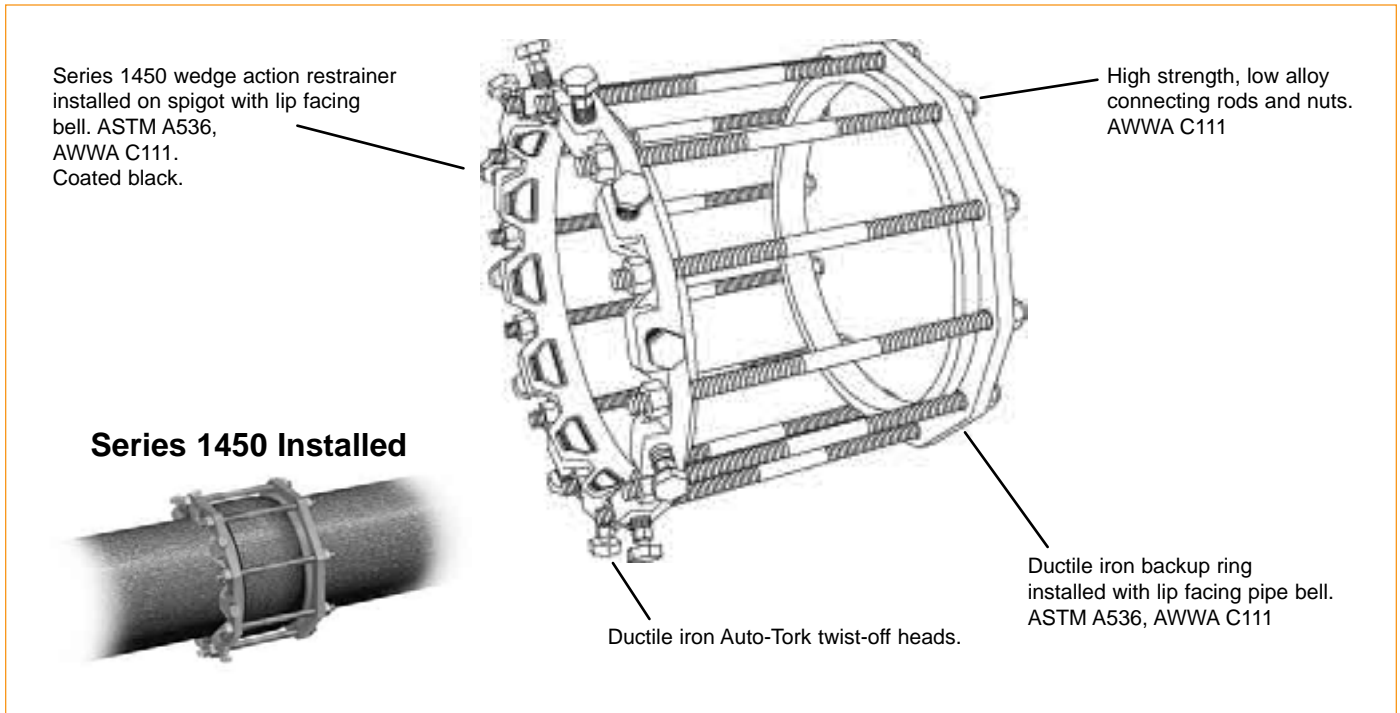

NOM. PIPE SIZE	PIPE O.D. (INCHES)	CATALOG NUMBER	PRESSURE RATING (PSI)	No. OF RODS	ROD LENGTH	ROD DIAMETER	*MAX. BELL DIAMETER	APPROX. WEIGHT (LBS)
3"	3.96	UFR1450-D-3-(I or U)	350	4	14"	5/8"	5.50	12.0
4"	4.80	UFR1450-D-4-(I or U)	350	4	17"	3/4"	6.62	19.5
6"	6.90	UFR1450-D-6-(I or U)	350	6	17"	3/4"	8.62	29.0
8"	9.05	UFR1450-D-8-(I or U)	350	6	17"	3/4"	10.88	34.5
10"	11.10	UFR1450-D-10-(I or U)	350	8	24"	3/4"	13.12	56.0
12"	13.20	UFR1450-D-12-(I or U)	350	8	24"	3/4"	15.38	62.0
14"	15.30	UFR1450-D-14-(I or U)	350	10	24"	3/4"	17.88	87.0
16"	17.40	UFR1450-D-16-(I or U)	350	12	24"	3/4"	20.12	107.0
18"	19.50	UFR1450-D-18-(I or U)	250	12	24"	3/4"	22.38	122.0
20"	21.60	UFR1450-D-20-(I or U)	250	14	24"	3/4"	24.62	140.0
24"	25.80	UFR1450-D-24-(I or U)	250	16	24"	3/4"	29.12	159.0
30"	32.00	UFR1450-D-30-(I or U)	250	20	24"	1"	35.80	362.0
36"	38.30	UFR1450-D-36-(I or U)	250	24	24"	1"	42.60	430.0

I = Import Casting U = Domestic Casting

All dimensions in inches unless otherwise stated.

* NOTE: Connecting rods **WILL NOT CLEAR** a pipe bell with a maximum diameter larger than the listed measurement. These diameters do not include joint deflection. Confirm pipe bell diameter before ordering.

Sample Specification - Series 1450

Restraint for push-on bells of ductile iron pipe shall consist of a wedge action retainer gland installed on the pipe spigot, connected to a ductile iron backup ring installed behind the pipe bell. The wedge action restrainer shall be manufactured of high strength ductile iron, ASTM A536, grade 65-45-12. Wedges shall be heat treated to a minimum BHN 370 and shall be contoured to properly fit the pipe. The heads of the wedge actuating screws shall twist off at the recommended torque, assuring correct installation. Connecting rods and nuts shall be of high strength, low alloy material meeting ANSI / AWWA C111 / A21.11 standard. The backup ring shall be of high strength ductile iron, ASTM A536, grade 65-45-12. Restrainers for push-on joints of ductile iron pipe shall carry a water working pressure rating of 350 psi in 3" through 16" sizes, 250 psi in 14" through 36" sizes, and shall be Uni-Flange® Series 1450 or approved equal.